

N30-45ZR₂/ZDR₂ N30-40ZRS₂/ZDRS₂ SERIES



**STRONG PARTNERS.
TOUGH TRUCKS.™**

NARROW AISLE, SINGLE & DOUBLE REACH, AC POWERED

NARROW AISLE REACH TRUCKS

Do the demands of your throughput seem unattainable? Hyster provides many ingenious products to solve your materials handling needs. No smoke. No mirrors. Just a simple philosophy to make our trucks better and tougher to last. The 80 year rich Hyster heritage is very evident in our latest evolutionary addition. Introducing our innovative and technically advanced Hyster® Narrow Aisle N30-40ZRS₂/ZDRS₂ and N30-45ZR₂/ZDR₂ series of single and double reach trucks.

These narrow aisle trucks are the culmination of a dedicated team of Hyster engineers who push the limits of continuous product improvement. The result is a series of Narrow Aisle lift trucks with the durability, serviceability, ergonomics, and performance benefits that will meet your operator's needs, help reduce costs and work to drive uptime and productivity.





■ DEPENDABILITY

- Redesigned Master Drive Unit
- Advanced Thermal Management System
- Heavy duty frame design
- Robust VISTA™ mast

■ LOW COST OF OWNERSHIP

- Low maintenance and extended service intervals
- Spring loaded caster assembly
- AC traction motor
- Hyster Tracker (Wireless Asset Management)

■ SERVICEABILITY

- CANbus controller
- Uncluttered operator compartment
- Hyster® i3 Technology™
- Service and parts availability

■ ERGONOMICS

- Optimized operator compartment
- Multifunction control handle
- Increased floor compartment size
- Suspended floorplate

■ PRODUCTIVITY

- Multifunction display
- Fore/aft automotive steering
- Power lowering
- Proportional reach/retract system

DEPENDABILITY

THERE'S NO QUIT IN A HYSTER® LIFT TRUCK

Before you take delivery of a new truck, you can be assured it's been put through a series of product proving tests and inspections before it arrives. So your Hyster® Narrow Aisle truck is built tough for years of dependability and service.

■ MASTER DRIVE UNIT

- Tapered motor input pinion shaft is fully lubricated by MDU gear oil
 - Service free design eliminates 3000 hour lubrication service. No additional services needed.
- Drive unit is sealed for life
 - No oil changes required
 - No break-in oil change
- New sealed turntable bearing
 - Greatly reduces the ingress of debris and increases bearing life



■ WORLD CLASS DEPENDABILITY

- The Hyster-designed thermal management system maximizes performance during continuous operation, while preventing damage to components due to heat.
- Base arms are welded to the frame, separate from mast assembly, for excellent structural strength. This unique design allows a mast to be easily interchanged. Toe cap protection on the base arms help protect load wheels from damage. Blunt style toe cap protection is standard on single reach trucks. Tapered style toe cap protection is standard on double reach trucks.
- The Hyster pantograph is designed using finite element analysis for durability. Rear frame and inner arm weldments are reinforced for added strength and rigidity.



AC Controller with Heat Sink



Basearms provide stability and strength



Hyster Pantograph Design

■ HEAVY DUTY DESIGN

- The unitized design and welded steel construction of the frame provide better rigidity and excellent protection for the internal components. The exceptional strength and durability of the frame are designed and tested using computer-generated Finite Element Analysis.
- Attention to detail such as our Leak-free O-ring face seal fittings and double-sealed waterproof electrical connectors provide enhanced reliability.
- The exclusive VISTA™ mast provides a superior life with low maintenance costs. Stress tested, hot-rolled mast channels give you a high-load carrying capacity. Nested channel design features durable, dual lift cylinders positioned behind channels for protection. Chrome plated cylinder rods resist corrosion and scoring. Side thrust wear plugs allow mast adjustment without the need for mast removal.

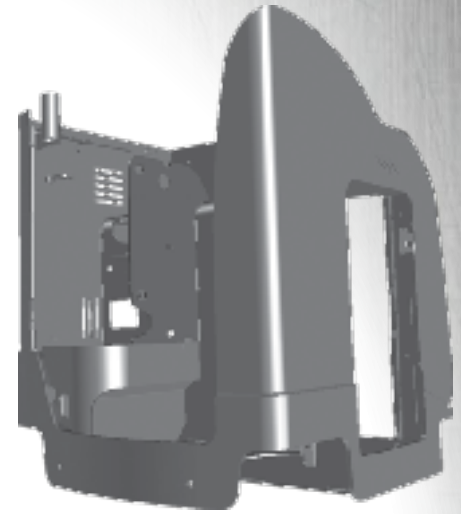

Heavy Duty Frame Design

You can rely on the strength of the pantograph. Its arms are made of one-inch thick alloy steel – thicker than many other models. That way, you can carry high capacity loads confidently and securely.

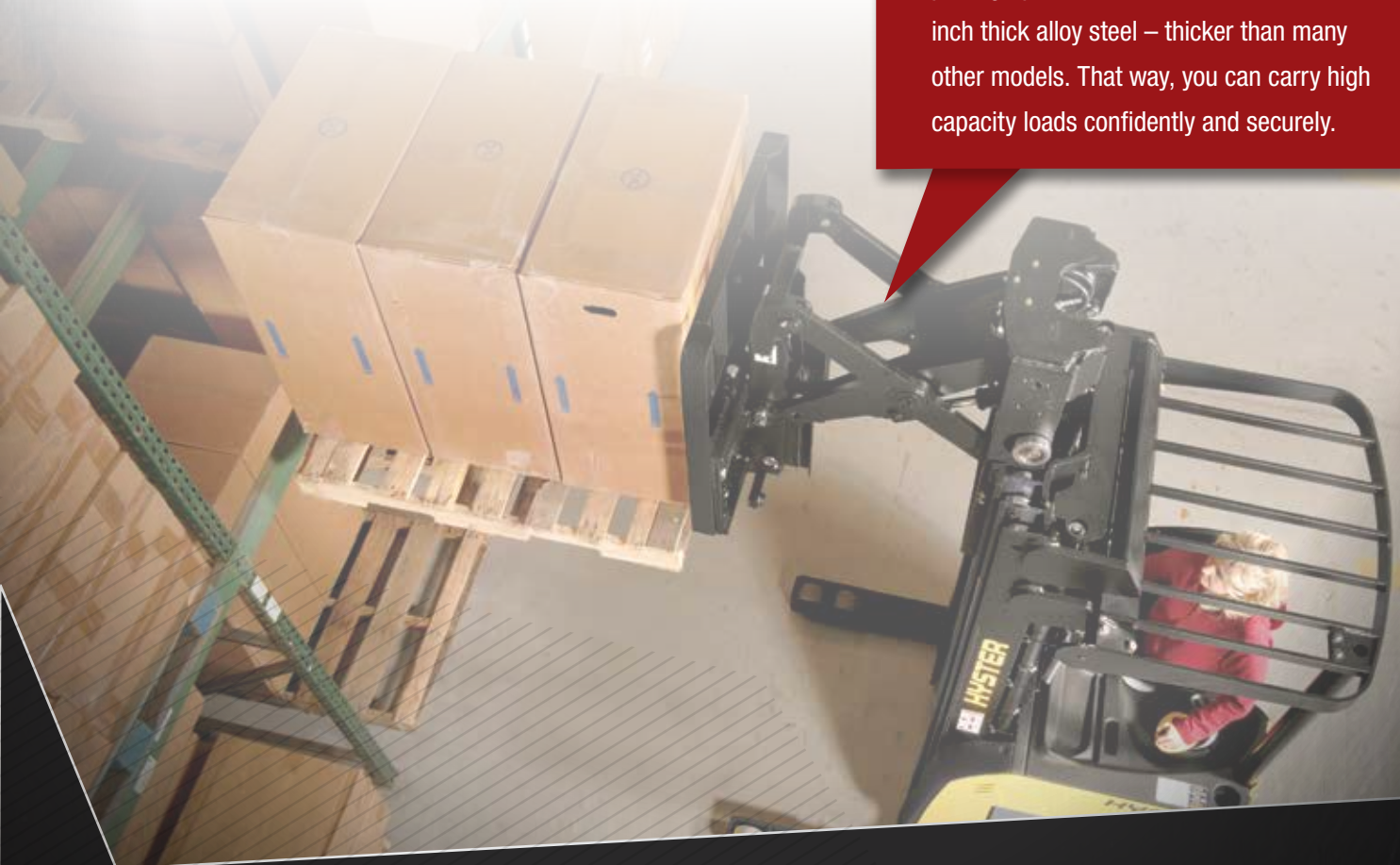

LOW COST OF OWNERSHIP

GIVING BACK IS WHAT HYSTER DOES BEST

The superior design of Hyster® reach trucks helps to lower your cost of ownership and increase productivity. Extended maintenance intervals, longer brake and tire life, all play a part in lowering the overall operating costs. Our reach trucks are designed and tested to stand up to your toughest applications, minimizing service interruptions, saving you money.

DESIGNED FOR SAVINGS

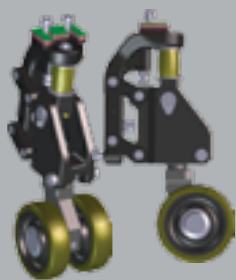

SPRING LOADED CASTER ASSEMBLY

- Helps maintain drive wheel contact with ground over floor cracks or uneven floors.
- Dual articulating wheels maintain ground contact with both wheels for even tire wear and minimize tire scrubbing when pivoting.

AC TRACTION MOTOR

- No more commutating brushes.
- The brushless design provides improved reliability and maintenance intervals.

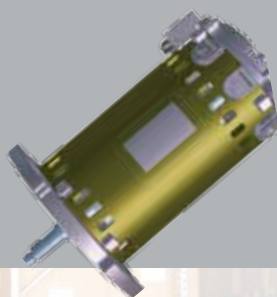

Stationary Drive Motor eliminates cable flexing during steering. Improved drive housing cover seal reduces chance for contamination

HYSTER TRACKER - WIRELESS ASSET MANAGEMENT

Take your fleet operation to the next level with wireless asset management from Hyster. Hyster Tracker provides a scalable solution for fleets. From monitoring truck utilization to limiting operator access, Hyster Tracker allows you to track your fleet at your fingertips.



TRACKER

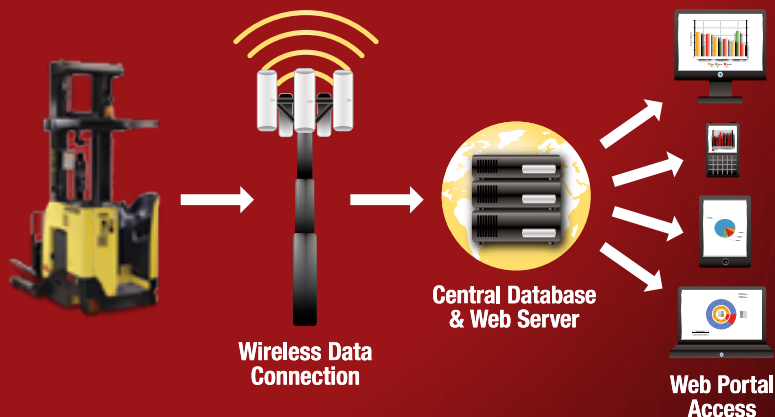

■ SUPERIOR SERVICEABILITY

- The N-ZRS₂/ZDRS₂ and N-ZR₂/ZDR₂ series utilizes Hyster® i³ Technology™ CANbus communications to simplify wiring and improve serviceability. The Integrated Intelligent Interface ties together functionality, software, diagnostic codes, similar interfaces, and is Hyster Tracker compatible.
- The swing-out compartment doors reveal an uncluttered, well laid out compartment making servicing easier. Stationary drive motor eliminates power cable flexing, improving cable reliability and longevity.
- CANbus controller reduces wiring by 40% and electrical connections by 25%, resulting in enhanced reliability and excellent visibility through the mast.



Uncluttered access to motor and controllers



Hyster® i³ Technology™ integrates commonality among Hyster warehouse products and simplifies the way in which operators and technicians alike handle and service the truck. This technology allows operator input to optimize performance to suit operator skill level. It also provides setup and diagnostic menus for service technicians.



Brass wear plugs allow periodic adjustments without mast disassembly. Wear strips keep the channel properly aligned reducing maintenance and providing greater uptime.

■ SUPPORTING CUSTOMERS WITH WORLD-CLASS PARTS & SERVICE

Four Parts Distribution Centers strategically located around the world provide a full range of original equipment and aftermarket parts that help maintain our customers' uptime. In fact, our Guaranteed Availability Program ensures that parts for all lift trucks within two years of age are available within 24 hours, 100% of the time.*

We also take that commitment into the field with the Hyster CERTECH® Certification training program. This technical training program provides both systems level as well as product-specific education to ensure lift trucks are repaired right the first time.



* Contact your local dealer for program details.

ERGONOMICALLY DESIGNED

A COMFORTABLE RIDE – HANDS DOWN

The *DriveRite* operator compartment is a truly flexible operator compartment. Available in standard forward stance or optional side stance configuration we have a truck for your application. The ability to assume variable positions within the operator compartment offers a comfortable and natural operating experience.

■ SUPERIOR OPERATOR COMFORT

- A generously sized compartment lets your operator move about easily yet feels secure, no matter your driving stance.
- Padded walls provide soft support for your hips and a 5/8" thick floor mat cushions your feet.
- The pressure-sensitive switch in the floor mat ensures that the operator has both feet inside the truck, before it can travel.



The multifunction control handle's unique shape and angle design helps minimize hand movements and muscle fatigue.



Convenient optional aft control handle improves operator convenience and comfort during operation.





Steer tiller handle position is operator adjustable (Opt. on ZRS₂) and steer effort is adjustable to reduce operator fatigue.



Operator console made of high impact ABS plastic, with convenient tray and clip for paperwork retention.



Optional Side stance control is configured with the operator in mind and offers simultaneous control of travel and hydraulic functions.

■ FLOOR COMPARTMENT

- 18% larger floor compartment than other major competitors.
- The large suspended floorplate provides room for movement and has no pedal to step over. The full 5/8" thick deep cushioned floor mat and floor plate rides on elastomeric mounts, cushioning the ride to reduce operator fatigue.
- The unique "step-up" brake allows the operator to enter and exit the compartment easily. The step height and flush mounted floor mat provides an uninterrupted entry into the compartment.
- Compartment offers an optional heated floor mat for SubZero conditions. Floor compartment is spacious and provides superior operator comfort.



The 9.5" step height, flush mounted switches are properly positioned for operator comfort.

Hyster has 18% larger floorspace

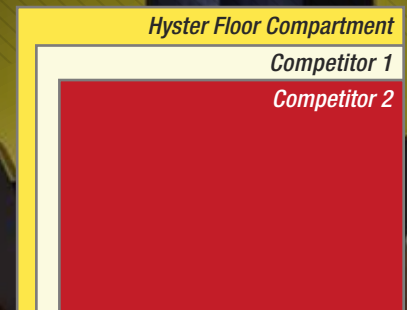
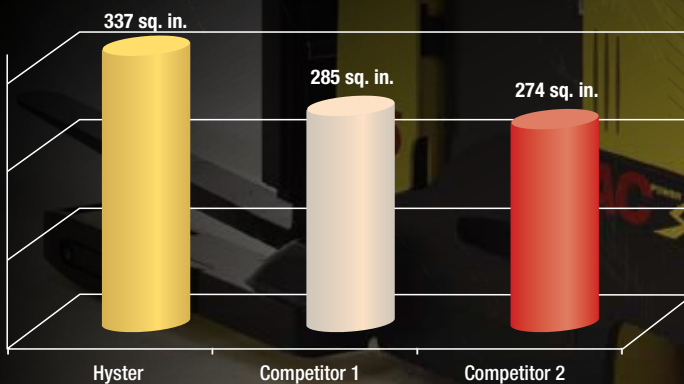

PRODUCTIVITY

ONLY 24 HOURS IN A DAY. MAKE THE MOST OF THEM.

Hyster® Reach Trucks work harder, longer and faster without compromising safety to make it one of the most productive lift trucks in the industry. The end result is a lift truck that increases throughput and sales volume while reducing operating costs.

■ SUPERIOR OPERATOR CONTROL

- Multifunction control handle offers simultaneous control of travel and hydraulic functions. A thumb-actuated vertically mounted joystick provides full proportional control of the hydraulic functions: lift/lower, reach/retract, tilt up/down.
- The Hyster VISTA™ mast provides smooth mast staging for stepless lifting and lowering of the mast. Mast rigidity and improved capacity to height are part of the innovative mast design. The mast features fast lift and lower speeds combined with superb visibility.
- The multifunction display features a large LCD backlit screen that shows truck status for quick and easy diagnostics.



*Multifunction
Control Handle*



Clear Mast Visibility



Multifunction Display

■ FORE/AFT AUTOMOTIVE STEERING

This exclusive feature provides automotive steering in both directions of travel without operators having to reverse steering input (forks first or forks trailing). This feature is only available on a Forward Stance truck ordered with the optional Aft Travel Control Handle and can be enabled by a qualified technician through the dash display.

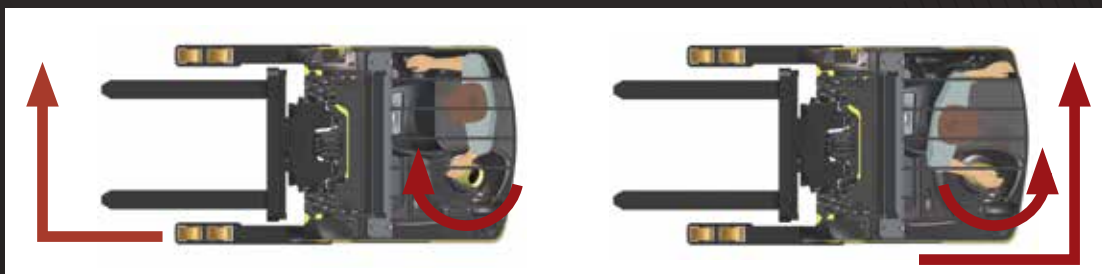

■ ENHANCED PRODUCTIVITY

- Powered lowering increases operator productivity by "powering" the load down when unloaded, maximizing lowering speeds.*
- Regenerative lowering helps reduce heat build-up in the hydraulic system and returns potential energy of the load to the battery to help increase battery shift life.*

* Available on the N/ZR₂ and ZDR₂.

■ AC TECHNOLOGY

- AC Technology delivers quick and smooth changes in travel direction and offers precise speed control with excellent acceleration thereby significantly increasing productivity potential.
- The standard "Extended Shift" feature allows enhanced run time without recharging over longer periods. The "Extended Shift" AC controller setting provides the optimum balance between performance needs and battery shift life.
- AC Technology features an Auto Deceleration System that, when activated, electronically decelerates the truck to a smooth stop when the operator moves the control handle towards neutral.
- The proportional reach/retract system provides efficient and precise load handling. Load cushioning is built into the extension and retraction cylinders to protect against load shock.

Load wheel box outer side-plates are flush mounted, reducing truck and rack catch points, available with blunt or tapered toe.

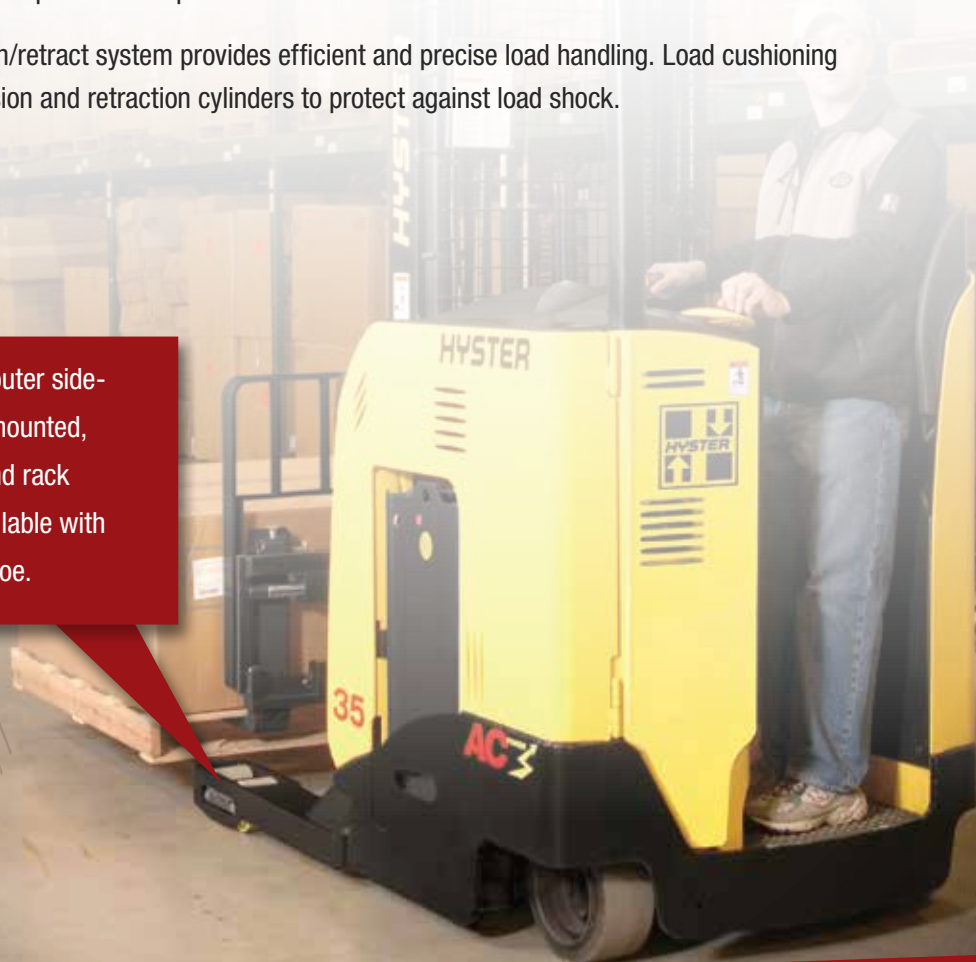

PERFORMANCE OPTIONS

CUSTOMIZED PERFORMANCE FOR ANY APPLICATION.

Tough applications come in all shapes and sizes. That's why Hyster Company gives you the option of tailoring your lift truck's performance and features to your application. Customize speed settings and choose from a wide array of options and accessories.

■ SIDE STANCE TRUCK

FEATURES:

- Large adjustable backrest pad with integral lumbar features 6" of adjustment vertically.
- Multifunction control assembly adjusts 3" horizontally in and out.



■ SIDE STANCE CONTROL HANDLE

FEATURES:

- Designed to be intuitive and productive
- New handle is 100% proportional providing precise control of loads, reducing product damage
- Provides operator a secure support point of contact when accelerating and decelerating
- Optional heater for operator comfort in SubZero applications
- All contact-less switches, allow individual serviceability



Optional Side stance control handle

■ SUPERIOR TRUCKS. SUPERIOR OPTIONS.

- Operator Front Lexan™ Shield
- Operator Overhead Fan
- Load Weight Display
- Impact Monitor
- Rear Operator's Compartment Door
- Application environmental construction
 - Standard construction: Operating temperatures: +32° to +120°F
 - Cooler/freezer package option: Operating temperatures: 0° to +120°F
 - SubZero freezer construction: Operating temperatures: -40° to +120°F
 - SubZero freezer with Heated Floor and Heated Multifunction Control Handle: Operating temperatures: -40° to +120°F



Fork Level Laser

- Mounted on the carriage.
- Projects a horizontal line at the same level of the forks.
- Turns on only when the forks are elevated 21" above Freelift.



Mounted Camera

- Camera assembly is attached to the carriage to give you a clear view of the fork entry into the pallet.
- Monitor can be mounted under the overhead guard on the left side of the operator compartment.

■ FULL CUBE UTILIZATION

By design, the Hyster double reach truck lets you handle twice as many pallets in a given aisle with a two deep rack system. As a result, the cost per pallet position is less, saving valuable storage space and racking. The truck is equipped with a reach mechanism having a stroke of 42" to handle a 48" long pallet.



INNOVATIVE TRUCKS ENGINEERED TO MEET THE MOST DEMANDING APPLICATIONS

For more than 80 years, Hyster has been conquering the world's most demanding applications. In the 1920's Hyster started as a manufacturer of lifting machines used in the rigorous logging industry of the United States' Pacific Northwest. A few years later the first fork lift trucks were invented and the Hyster® brand quickly gained its reputation for rugged quality. Hyster® lift trucks are designed to lower your cost of operations. Every truck we make — gasoline, LPG, diesel and electric — is purpose-built to excel in its application. Every truck is also backed by an unmatched network of specialists.



Dealer Network — Through our Dealer Network, we can offer the expertise of fleet managers, parts suppliers, capital procurement specialists and trainers. Hyster's carefully chosen dealers — and the people they employ — fully understand customer applications, assist in selecting the right lift truck and provide fast, reliable support after the sale.



Hyster Fleet Services — Even if you operate other brands, we can manage your maintenance and replacement plan. We can offer complete fleet analysis, fleet history summary and a cost-effective proposal for replacement and scheduled maintenance.



Parts — With genuine Hyster replacement parts and UNISOURCE™ parts for all makes of lift trucks, we are your one-stop source for lift truck parts. In fact, we offer more than 2 million part number crosses for most brands of materials handling and other in-plant mobile equipment.



Rental Products — When leasing or buying isn't a practical option, we have access to more than 14,000 units for short- and long-term rental. We'll help you maintain output in a cost-effective manner.



Hyster Capital — We can arrange solutions for special financing requirements, taking the difficulties out of buying the equipment you need. Whether you purchase or lease a new or used lift truck, Hyster Capital offers superior service and competitive rates.



Special Products Engineering Department (SPED) — Different materials require different handling. That's why we can work with you to customize your lift trucks. From strobe lights to specially made forks, SPED has the tools to help you get the job done right.



Operator Training — Proper education in operating lift trucks minimizes the risk of injuries due to accidents while increasing productivity. Hyster offers OSHA-compliant materials that support the training of qualified operators.



Service — Your local Hyster dealer offers a flexible, customized and comprehensive maintenance plan based on each lift truck's application, make, model and operation environment. Hyster service programs offer scheduled inspections and maintenance, and when you need immediate service on a fleet or single truck, your local dealer offers quick, responsive service dispatched to your location.





Hyster Company
P.O. Box 7006
Greenville, North Carolina
27835-7006
Part No. REACH/B
10/2014 Litho in U.S.A.

Visit us online at www.hyster.com/americas or call us at **1-800-HYSTER-1**.

Hyster, and  are registered trademarks of Hyster Company.
Hyster products are subject to change without notice.

The Hyster Company product included in this document may be covered by U.S. Patent 6,684,148 and other patents pending.
All trucks shown with optional equipment. © 2014 Hyster Company. All rights reserved.