



**STRONG PARTNERS.  
TOUGH TRUCKS.™**



# R1.4–2.5 SERIES TECHNICAL GUIDE

[WWW.HYSTER.COM](http://WWW.HYSTER.COM)

# > R SERIES DIMENSIONS

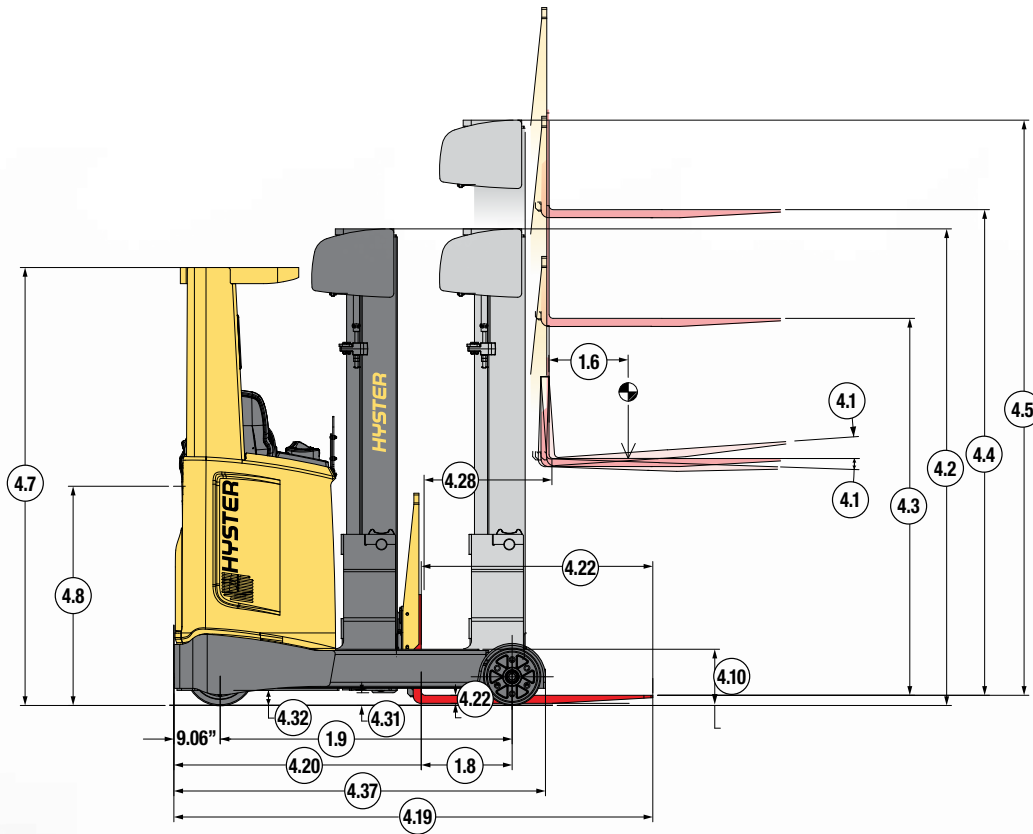

**a = Clearance = 8"**  
**L6 = Load Length**  
**b12 = Load width**  
**AST = Wa + R + a**  
**AST = Right Angle Stack**

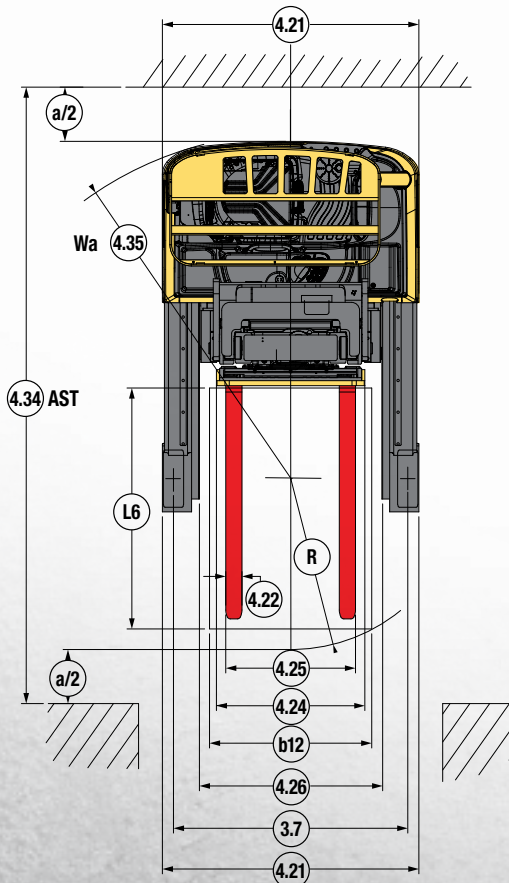
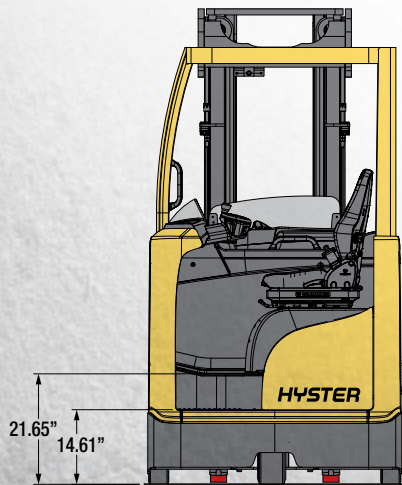

*Circled dimensions correspond to the line numbers on the tabulated chart inside the Technical Guide. Dimensions are in inches (millimeters).*

# R SERIES SPECIFICATIONS



		Hyster				
		R1.4	R1.6			
GENERAL	1.1	Manufacturer (abbreviation)				
	1.2	Manufacturer's type designation				
	1.3	Drive: electric, diesel, petrol, fuel gas				
	1.4	Operator type				
WEIGHT	1.5	Rated capacity/rated load	lb (kg)	3000 (1400)	3500 (1600)	
	1.6	Load center distance	in (mm)	24 (600)		
	1.8	Load distance, center of drive axle to fork	in (mm)	15.83 (402)	17.80 (452)	
	1.9	Wheelbase	in (mm)	55.12 (1400)	57.09 (1450)	
	2.1	Service weight	lb (kg)	6861 (3112)	6971 (3162)	
WHEELS/TIRES	2.2	Axle loading, NL front/rear <sup>4</sup>	lb (kg)	4359/2502 (1977/1135)	4449/2522 (2018/1144)	
	2.3	Axle loading fork advanced, RL front/rear	lb (kg)	1504/8444 (682/3830)	1325/9176 (601/4162)	
	2.4	Axle loading fork retracted, RL front/rear	lb (kg)	3920/6030 (1778/2735)	4085/6413 (1853/2909)	
	2.5	Tires, front/rear		Vulkollan/Vulkollan		
	3.1	Tire size, front	in (mm)	13.5 x 5.5 (343 x 140)		
DIMENSIONS	3.2	Tire size, rear	in (mm)	11.2 x 3.9 (285 x 100)		
	3.3	Wheels, number front/rear (x = driven wheels)		1x/2		
	3.4	Tread, rear	in (mm)	45.47 (1155)		
	3.5	Tilt of mast/fork carriage forward/backward	degrees	2/4		
	3.6	Height of mast, lowered	in (mm)	See Mast Tables		
	3.7	Free lift	in (mm)	See Mast Tables		
	3.8	Lift	in (mm)	See Mast Tables		
	3.9	Height, mast extended <sup>1</sup>	in (mm)	See Mast Tables		
	3.10	Height of overhead guard (cabin) <sup>2</sup>	in (mm)	85.63 (2175)		
	3.11	Seat height relating to SIP	in (mm)	42.60 (1082)		
	3.12	Height of wheel arms	in (mm)	12.13 (308)		
	3.13	Overall length	in (mm)	93.66 (2379)		
	3.14	Length to face of forks	in (mm)	48.39 (1229)		
	3.15	Overall width <sup>3</sup>	in (mm)	49.80 (1265)		
	3.16	Fork dimensions DIN ISO 2331	in (mm)	1.6/3.1/45.3 (40/80/1150)	1.6/4.7/45.3 (40/120/1150)	
	3.17	Fork carriage ISO 2328, class/type A, B		2A		
	3.18	Fork carriage width	in (mm)	27.56 (700)		
	3.19	Distance between fork arms, min/max <sup>7</sup>	in (mm)	8.66/25.20 (220/640)	10.24/26.77 (260/680)	
	3.20	Distance between wheel arms/loading surfaces	in (mm)	35.43 (900)		
	3.21	Reach distance	in (mm)	23.03 (585)	25.0 (635)	
	3.22	Ground clearance, RL, below mast	in (mm)	2.95 (75)		
	3.23	Ground clearance, center of wheelbase	in (mm)	2.95 (75)		
	3.24	Aisle width for pallets 39.3"x47.2" (1000mm x 1200mm) across - (L6 xb12)	in (mm)	107.0 (2718) - See Charts	107.5 (2731) - See Charts	
	3.25	Aisle width for pallets 31.5"x47.2" (800mm x 1200mm) lengthwise - (b12 x L6)	in (mm)	108.8 (2764) - See Charts	108.9 (2767) - See Charts	
	3.26	Turning radius (Wa)	in (mm)	65.79 (1671)	67.64 (1718)	
	3.27	Length across wheel arms	in (mm)	70.67 (1795)	72.64 (1845)	
	3.28	Step height (from ground to running board)	in (mm)	21.65 (550)		
	3.29	Step height (between intermediate steps between running board and floor)	in (mm)	14.61 (371)		
	PERFORMANCE DATA	3.30	Travel speed, RL   NL <sup>6</sup> Std {Opt}	mph (km/h)	6.8/6.8 (11/11) {8.7/8.7 (14/14)}	
		3.31	Travel speed, RL   NL, backwards <sup>8</sup> Std {Opt}	mph (km/h)	6.8/6.8 (11/11) {8.7/8.7 (14/14)}	
3.32		Lift speed, RL   NL <sup>6</sup> Std {Opt}	ft/min (m/s)	72.8/124 (0.37/0.63) {92.5/143.7 (0.47/0.73)}	63/124 (0.32/0.63) {82.7/143.7 (0.42/0.73)}	
3.33		Lowering speed, RL/NL	ft/min (m/s)	108.3 (0.55/0.55)		
3.34		Reaching speed, RL/NL	ft/min (m/s)	33.5/33.5 (0.17/0.17)		
3.35		Gradeability, RL/NL	%	10/15		
3.36		Max. gradeability RL/NL	%	10/15		
3.37		Service brake		Electric		
3.38		Drive motor, S2 60 minute rating	kW	6.4		
3.39		Lift motor, S3 15% rating	kW	14		
ELECTRIC	3.40	Battery voltage/nominal capacity	(V)/(Ah)	48/420 <sup>5</sup>		
	3.41	Battery weight <sup>8</sup>	lb (kg)	1653 (750)		
	3.42	Type of drive unit		AC		
	3.43	Operating pressure for attachments	bar	180		
OTHER	3.44	Oil volume for attachment	l/min	20		
	3.45	Sound pressure level at the driver's seat	dB(A)	< 69.7		

<sup>1</sup> With load backrest add 20" (R1.4-R1.6-R1.6N-R1.6HD), add 17.44" (R2.0-R2.5-R2.0HD).

<sup>2</sup> With beacon add 4.72"; with OHG grid protector add 0.79"; with OHG screen protector add 1.18".

<sup>3</sup> With load wheels lateral covers: 50.78" (R1.4-R1.6-R2.0-R1.6HD), 45.39" (R1.6N), 54.06" (R2.5-R2.0HD).

<sup>4</sup> Forks retracted.

<sup>5</sup> See battery tables.

<sup>6</sup> Values in brackets { } are optional.

<sup>7</sup> Side shift stroke is +/-2.95" on all trucks. Reduced to +/-0.98" for R1.6N.

<sup>8</sup> These values may vary of +/- 5%.

RL = Rated Load, NL = No Load

† NOTE: Performance specifications/ratings are for truck equipped as described under Standard Equipment in this Specification Sheet. Performance specifications are affected by the condition of the vehicle and how it is equipped, as well as by the nature and condition of the operating area. Specifications are subject to change and the proposed application should be discussed with your authorized Hyster® dealer.

†† All values are nominal values and are subject to tolerances. For further information on this dimension, please contact your local Hyster® dealer.

Above specifications, unless otherwise listed, are for a standard truck without optional equipment.

Hyster® products are subject to change without notice. Lift trucks illustrated may feature optional equipment.

See truck dimensions for batteries chart.



# R SERIES SPECIFICATIONS

			Hyster R1.6N	Hyster R1.6HD	
GENERAL	1.1	Manufacturer (abbreviation)			
	1.2	Manufacturer's type designation			
	1.3	Drive: electric, diesel, petrol, fuel gas	Electric (battery)	Electric (battery)	
	1.4	Operator type	Seated	Seated	
	1.5	Rated capacity/rated load	3500 (1600)	3500 (1600)	
	1.6	Load center distance	24 (600)	24 (600)	
	1.8	Load distance, center of drive axle to fork	15.04 (382)	12.13 (308)	
	1.9	Wheelbase	57.09 (1450)	57.09 (1450)	
	WEIGHT	2.1	Service weight	6859 (3111)	8902 (4038)
2.3		Axle loading, NL front/rear <sup>4</sup>	4237/2621 (1922/1189)	5329/3574 (2417/1621)	
2.4		Axle loading fork advanced, RL front/rear	1254/9132 (569/4142)	1947/10483 (883/4755)	
2.5		Axle loading fork retracted, RL front/rear	3704/6684 (1680/3032)	4788/7641 (2172/3466)	
WHEELS/TIRES		3.1	Tires, front/rear	Vulkollan/Vulkollan	Vulkollan/Vulkollan
	3.2	Tire size, front	13.5 x 5.5 (343 x 140)	13.5 x 5.5 (343 x 140)	
	3.3	Tire size, rear	11.2 x 3.9 (285 x 100)	11.2 x 3.9 (285 x 100)	
	3.5	Wheels, number front/rear (x = driven wheels)	1x/2	1x/2	
	3.7	Tread, rear	40.35 (1025)	45.47 (1155)	
	DIMENSIONS	4.1	Tilt of mast/fork carriage forward/backward	2/4	2/4
		4.2	Height of mast, lowered	See Mast Tables	See Mast Tables
		4.3	Free lift	See Mast Tables	See Mast Tables
		4.4	Lift	See Mast Tables	See Mast Tables
		4.5	Height, mast extended <sup>1</sup>	See Mast Tables	See Mast Tables
4.7		Height of overhead guard (cabin) <sup>2</sup>	85.63 (2175)	85.63 (2175)	
4.8		Seat height relating to SIP	42.60 (1082)	42.60 (1082)	
4.10		Height of wheel arms	12.13 (308)	12.13 (308)	
4.19		Overall length	96.40 (2449)	99.31 (2523)	
4.20		Length to face of forks	51.14 (1299)	54.04 (1373)	
4.21		Overall width <sup>3</sup>	44.29 (1125)	49.80 (1265)	
4.22		Fork dimensions DIN ISO 2331	1.6/4.7/45.3 (40/120/1150)	1.6/4.7/45.3 (40/120/1150)	
4.23		Fork carriage ISO 2328, class/type A, B	2A	2A	
4.24		Fork carriage width	27.56 (700)	27.56 (700)	
4.25		Distance between fork arms, min/max <sup>7</sup>	10.24/26.77 (260/680)	10.24/26.77 (260/680)	
4.26		Distance between wheel arms/loading surfaces	31.30 (795)	35.43 (900)	
4.28		Reach distance	22.24 (565)	19.33 (491)	
4.31		Ground clearance, RL, below mast	2.95 (75)	2.56 (65)	
4.32		Ground clearance, center of wheelbase	2.95 (75)	2.56 (65)	
4.34.1		Aisle width for pallets 39.3"x47.2" (1000mm x 1200mm) across - (L6 x b12)	108.7 (2762) - See Charts	111.57 (2834) - See Charts	
4.34.2		Aisle width for pallets 31.5"x47.2" (800mm x 1200mm) lengthwise - (b12 x L6)	110.7 (2811) - See Charts	114.02 (2896) - See Charts	
4.35		Turning radius (Wa)	66.93 (1700)	67.64 (1718)	
4.37		Length across wheel arms	72.64 (1845)	72.64 (1845)	
4.42		Step height (from ground to running board)	21.65 (550)	21.65 (550)	
4.43		Step height (between intermediate steps between running board and floor)	14.61 (371)	14.61 (371)	
PERFORMANCE DATA		5.1	Travel speed, RL   NL <sup>6</sup> Std {Opt}	6.8/6.8 (11/11) {8.7/8.7 (14/14)}	8.7/8.7 (14/14)
		5.1.1	Travel speed, RL   NL, backwards <sup>6</sup> Std {Opt}	6.8/6.8 (11/11) {8.7/8.7 (14/14)}	8.7/8.7 (14/14)
	5.2	Lift speed, RL   NL <sup>6</sup> Std {Opt}	63/124 (0.32/0.63) {82.7/143.7 (0.42/0.73)}	82.7/143.7 (0.42/0.73)	
	5.3	Lowering speed, RL/NL	108.3/108.3 (0.55/0.55)	108.3/108.3 (0.55/0.55)	
	5.4	Reaching speed, RL/NL	33.5/33.5 (0.17/0.17)	33.5/33.5 (0.17/0.17)	
	5.7	Gradeability, RL/NL	10/15	10/14	
	5.8	Max. gradeability RL/NL	10/15	10/15	
	5.10	Service brake	Electric	Electric	
	ELECTRIC	6.1	Drive motor, S2 60 minute rating	6.4	6.4
		6.2	Lift motor, S3 15% rating	14	14
6.4		Battery voltage/nominal capacity	48/420 <sup>5</sup>	48/560 <sup>5</sup>	
6.5		Battery weight <sup>8</sup>	1653 (750)	2070 (939)	
OTHER		8.1	Type of drive unit	AC	AC
	10.1	Operating pressure for attachments	180	180	
	10.2	Oil volume for attachment	20	20	
	10.7	Sound pressure level at the driver's seat	< 69.7	< 69.7	

<sup>1</sup> With load backrest add 20" (R1.4-R1.6-R1.6N-R1.6HD), add 17.44" (R2.0-R2.5-R2.0HD).

<sup>2</sup> With beacon add 4.72"; with OHG grid protector add 0.79"; with OHG screen protector add 1.18".

<sup>3</sup> With load wheels lateral covers: 50.78" (R1.4-R1.6-R2.0-R1.6HD), 45.39" (R1.6N), 54.06" (R2.5-R2.0HD).

<sup>4</sup> Forks retracted.

<sup>5</sup> See battery tables.

<sup>6</sup> Values in brackets { } are optional.

<sup>7</sup> Side shift stroke is +/-2.95" on all trucks. Reduced to +/-0.98" for R1.6N.

<sup>8</sup> These values may vary of +/- 5%.

RL = Rated Load, NL = No Load

† NOTE: Performance specifications/ratings are for truck equipped as described under Standard Equipment in this Specification Sheet. Performance specifications are affected by the condition of the vehicle and how it is equipped, as well as by the nature and condition of the operating area. Specifications are subject to change and the proposed application should be discussed with your authorized Hyster® dealer.

†† All values are nominal values and are subject to tolerances. For further information on this dimension, please contact your local Hyster® dealer.

Above specifications, unless otherwise listed, are for a standard truck without optional equipment.

Hyster® products are subject to change without notice. Lift trucks illustrated may feature optional equipment.

See truck dimensions for batteries chart.

# R SERIES SPECIFICATIONS



			Hyster	Hyster	
GENERAL	1.1	Manufacturer (abbreviation)	R2.0	R2.0HD	
	1.2	Manufacturer's type designation			
	1.3	Drive: electric, diesel, petrol, fuel gas	Electric (battery)	Electric (battery)	
	1.4	Operator type	Seated	Seated	
	1.5	Rated capacity/rated load	4500 (2000)	4500 (2000)	
	1.6	Load center distance	24 (600)	24 (600)	
	1.8	Load distance, center of drive axle to fork	16.93 (430)	13.90 (353)	
	1.9	Wheelbase	59.06 (1500)	59.06 (1500)	
	WEIGHT	2.1	Service weight	7970 (3615)	9755 (4425)
2.3		Axle loading, NL front/rear <sup>4</sup>	4985/2985 (2261/1354)	5659/4096 (2567/1858)	
2.4		Axle loading fork advanced, RL front/rear	1479/10897 (671/4943)	1964/12200 (891/5534)	
2.5		Axle loading fork retracted, RL front/rear	4480/7899 (2032/3583)	4927/9235 (2235/4189)	
WHEELS/TIRES		3.1	Tires, front/rear	Vulkollan/Vulkollan	Vulkollan/Vulkollan
	3.2	Tire size, front	13.5 x 5.5 (343 x 140)	13.5 x 5.5 (343 x 140)	
	3.3	Tire size, rear	11.2 x 3.9 (285 x 100)	11.2 x 5.5 (285 x 140)	
	3.5	Wheels, number front/rear (x = driven wheels)	1x/2 1x/2	1x/2 1x/2	
	3.7	Tread, rear	45.47 (1155)	47.05 (1195)	
	4.1	Tilt of mast/fork carriage forward/backward	degrees	2/4	
	4.2	Height of mast, lowered	in (mm)	See Mast Tables	
DIMENSIONS	4.3	Free lift	in (mm)	See Mast Tables	
	4.4	Lift	in (mm)	See Mast Tables	
	4.5	Height, mast extended <sup>1</sup>	in (mm)	See Mast Tables	
	4.7	Height of overhead guard (cabin) <sup>2</sup>	in (mm)	85.63 (2175)	
	4.8	Seat height relating to SIP	in (mm)	42.60 (1082)	
	4.10	Height of wheel arms	in (mm)	12.13 (308)	
	4.19	Overall length	in (mm)	96.50 (2451)	
	4.20	Length to face of forks	in (mm)	51.22 (1301)	
	4.21	Overall width <sup>3</sup>	in (mm)	49.80 (1265)	
	4.22	Fork dimensions DIN ISO 2331	in (mm)	1.6/4.7/45.3 (40/120/1150)	
	4.23	Fork carriage ISO 2328, class/type A, B		2A	
	4.24	Fork carriage width	in (mm)	27.56 (700)	
	4.25	Distance between fork arms, min/max <sup>7</sup>	in (mm)	10.24/26.77 (260/680)	
	4.26	Distance between wheel arms/loading surfaces	in (mm)	35.43 (900)	
	4.28	Reach distance	in (mm)	24.13 (613)	
	4.31	Ground clearance, RL, below mast	in (mm)	2.56 (65)	
	4.32	Ground clearance, center of wheelbase	in (mm)	2.56 (65)	
	4.34.1	Aisle width for pallets 39.3"x47.2" (1000mm x 1200mm) across - (L6 x b12)	in (mm)	110 (2795) - See Charts	
	4.34.2	Aisle width for pallets 31.5"x47.2" (800mm x 1200mm) lengthwise - (b12 x L6)	in (mm)	111.6 (2835) - See Charts	
	4.35	Turning radius (Wa)	in (mm)	69.57 (1767)	
	4.37	Length across wheel arms	in (mm)	74.61 (1895)	
4.42	Step height (from ground to running board)	in (mm)	21.65 (550)		
4.43	Step height (between intermediate steps between running board and floor)	in (mm)	14.61 (371)		
PERFORMANCE DATA	5.1	Travel speed, RL   NL <sup>8</sup>	mph (km/h)	8.7/8.7 (14/14)	
	5.1.1	Travel speed, RL   NL, backwards <sup>6</sup>	mph (km/h)	8.7/8.7 (14/14)	
	5.2	Lift speed, RL   NL <sup>8</sup>	ft/min (m/s)	72.8/126 (0.37/0.64)	
	5.3	Lowering speed, RL/NL	ft/min (m/s)	108.3/98.4 (0.55/0.50)	
	5.4	Reaching speed, RL/NL	ft/min (m/s)	33.5/33.5 (0.17/0.17)	
	5.7	Gradeability, RL/NL	%	10/15	
	5.8	Max. gradeability RL/NL	%	10/15	
	5.10	Service brake		Electric	
	ELECTRIC	6.1	Drive motor, S2 60 minute rating	kW	6.4
		6.2	Lift motor, S3 15% rating	kW	14
6.4		Battery voltage/nominal capacity	(V)/Ah	48/560 <sup>5</sup>	
6.5		Battery weight <sup>8</sup>	lb (kg)	2070 (939)	
OTHER		8.1	Type of drive unit		AC
	10.1	Operating pressure for attachments	bar	180	
	10.2	Oil volume for attachment	l/min	20	
	10.7	Sound pressure level at the driver's seat	dB(A)	<69.7	

<sup>1</sup> With load backrest add 20" (R1.4-R1.6-R1.6N-R1.6HD), add 17.44" (R2.0-R2.5-R2.0HD).

<sup>2</sup> With beacon add 4.72"; with OHG grid protector add 0.79"; with OHG screen protector add 1.18".

<sup>3</sup> With load wheels lateral covers: 50.78" (R1.4-R1.6-R2.0-R1.6HD), 45.39" (R1.6N), 54.06" (R2.5-R2.0HD).

<sup>4</sup> Forks retracted.

<sup>5</sup> See battery tables.

<sup>6</sup> Values in brackets { } are optional.

<sup>7</sup> Side shift stroke is +/-2.95" on all trucks. Reduced to +/-0.98" for R1.6N.

<sup>8</sup> These values may vary of +/- 5%.

RL = Rated Load, NL = No Load

† NOTE: Performance specifications/ratings are for truck equipped as described under Standard Equipment in this Specification Sheet. Performance specifications are affected by the condition of the vehicle and how it is equipped, as well as by the nature and condition of the operating area. Specifications are subject to change and the proposed application should be discussed with your authorized Hyster® dealer.

†† All values are nominal values and are subject to tolerances. For further information on this dimension, please contact your local Hyster® dealer.

Above specifications, unless otherwise listed, are for a standard truck without optional equipment.

Hyster® products are subject to change without notice. Lift trucks illustrated may feature optional equipment.

See truck dimensions for batteries chart.



# R SERIES SPECIFICATIONS

				Hyster		
GENERAL	1.1	Manufacturer (abbreviation)		Hyster		
	1.2	Manufacturer's type designation		R2.5		
	1.3	Drive: electric, diesel, petrol, fuel gas		Electric (battery)		
	1.4	Operator type		Seated		
	1.5	Rated capacity/rated load	lb (kg)	5500 (2500)		
	1.6	Load center distance	in (mm)	24 (600)		
	1.8	Load distance, center of drive axle to fork	in (mm)	19.80 (503)		
	1.9	Wheelbase	in (mm)	64.96 (1650)		
	WEIGHT	2.1	Service weight	lb (kg)	8902 (4038)	
2.3		Axle loading, NL front/rear <sup>4</sup>	lb (kg)	5556/3347 (2520/1518)		
2.4		Axle loading fork advanced, RL front/rear	lb (kg)	1704/12710 (773/5765)		
2.5		Axle loading fork retracted, RL front/rear	lb (kg)	5227/9187 (2371/4167)		
WHEELS/TIRES		3.1	Tires, front/rear		Vulkollan/Vulkollan	
	3.2	Tire size, front	in (mm)	13.5 x 5.5 (343 x 140)		
	3.3	Tire size, rear	in (mm)	11.2 x 5.5 (285 x 140)		
	3.5	Wheels, number front/rear (x = driven wheels)		1x/2		
	3.7	Tread, rear	in (mm)	47.05 (1195)		
	4.1	Tilt of mast/fork carriage forward/backward	degrees	2/4		
	4.2	Height of mast, lowered	in (mm)	See Mast Tables		
DIMENSIONS	4.3	Free lift	in (mm)	See Mast Tables		
	4.4	Lift	in (mm)	See Mast Tables		
	4.5	Height, mast extended <sup>1</sup>	in (mm)	See Mast Tables		
	4.7	Height of overhead guard (cabin) <sup>2</sup>	in (mm)	85.63 (2175)		
	4.8	Seat height relating to SIP	in (mm)	42.60 (1082)		
	4.10	Height of wheel arms	in (mm)	12.13 (308)		
	4.19	Overall length	in (mm)	99.53 (2528)		
	4.20	Length to face of forks	in (mm)	54.25 (1378)		
	4.21	Overall width <sup>3</sup>	in (mm)	52.95 (1345)		
	4.22	Fork dimensions DIN ISO 2331	in (mm)	1.8/4.7/45.3 (45/120/1150)		
	4.23	Fork carriage ISO 2328, class/type A, B		2A		
	4.24	Fork carriage width	in (mm)	27.56 (700)		
	4.25	Distance between fork arms, min/max <sup>7</sup>	in (mm)	10.24/26.77 (260/680)		
	4.26	Distance between wheel arms/loading surfaces	in (mm)	35.43 (900)		
	4.28	Reach distance	in (mm)	27.0 (686)		
	4.31	Ground clearance, RL, below mast	in (mm)	2.56 (65)		
	4.32	Ground clearance, center of wheelbase	in (mm)	2.56 (65)		
	4.34.1	Aisle width for pallets 39.3"x47.2" (1000mm x 1200mm) across - (L6 x b12)	in (mm)	113.8 (2890) - See Charts		
	4.34.2	Aisle width for pallets 31.5"x47.2" (800mm x 1200mm) lengthwise - (b12 x L6)	in (mm)	114.8 (2915) - See Charts		
	4.35	Turning radius (Wa)	in (mm)	75.24 (1911)		
	4.37	Length across wheel arms	in (mm)	80.51 (2045)		
4.42	Step height (from ground to running board)	in (mm)	21.65 (550)			
4.43	Step height (between intermediate steps between running board and floor)	in (mm)	14.61 (371)			
PERFORMANCE DATA	5.1	Travel speed, RL   NL <sup>6</sup>	mph (km/h)	8.7/8.7 (14/14)		
	5.1.1	Travel speed, RL   NL, backwards <sup>6</sup>	mph (km/h)	8.7/8.7 (14/14)		
	5.2	Lift speed, RL   NL <sup>6</sup>	ft/min (m/s)	59.1/126 (0.30/0.64)		
	5.3	Lowering speed, RL/NL	ft/min (m/s)	108.3/98.4 (0.55/0.50)		
	5.4	Reaching speed, RL/NL	ft/min (m/s)	33.5/33.5 (0.17/0.17)		
	5.7	Gradeability, RL/NL	%	8/14		
	5.8	Max. gradeability RL/NL	%	10/15		
	5.10	Service brake		Electric		
	ELECTRIC	6.1	Drive motor, S2 60 minute rating	kW	6.4	
		6.2	Lift motor, S3 15% rating	kW	14	
6.4		Battery voltage/nominal capacity	(V)(Ah)	48/700 <sup>5</sup>		
6.5		Battery weight <sup>8</sup>	lb (kg)	2467 (1119)		
8.1		Type of drive unit		AC		
OTHER	10.1	Operating pressure for attachments	bar	180		
	10.2	Oil volume for attachment	l/min	20		
	10.7	Sound pressure level at the driver's seat	dB(A)	<69.7		

<sup>1</sup> With load backrest add 20" (R1.4-R1.6-R1.6N-R1.6HD), add 17.44" (R2.0-R2.5-R2.0HD).

<sup>2</sup> With beacon add 4.72"; with OHG grid protector add 0.79"; with OHG screen protector add 1.18".

<sup>3</sup> With load wheels lateral covers: 50.78" (R1.4-R1.6-R2.0-R1.6HD), 45.39" (R1.6N), 54.06" (R2.5-R2.0HD).

<sup>†</sup> NOTE: Performance specifications/ratings are for truck equipped as described under Standard Equipment in this Specification Sheet. Performance specifications are affected by the condition of the vehicle and how it is equipped, as well as by the nature and condition of the operating area. Specifications are subject to change and the proposed application should be discussed with your authorized Hyster® dealer.

<sup>††</sup> All values are nominal values and are subject to tolerances. For further information on this dimension, please contact your local Hyster® dealer.

Above specifications, unless otherwise listed, are for a standard truck without optional equipment.

Hyster® products are subject to change without notice. Lift trucks illustrated may feature optional equipment.

See truck dimensions for batteries chart.

<sup>4</sup> Forks retracted.

<sup>5</sup> See battery tables.

<sup>6</sup> Values in brackets { } are optional.

<sup>7</sup> Side shift stroke is +/-2.95" on all trucks. Reduced to +/-0.98" for R1.6N.

<sup>8</sup> These values may vary of +/- 5%.

RL = Rated Load, NL = No Load



<b>R1.4, R1.6, R1.6N - MAST DETAILS, 3-STAGE FULL FREE LIFT</b>				
<b>Model</b>	<b>Lift (4.4)</b>	<b>Free Lift (4.3)</b>	<b>Height of Mast Lowered (4.2)</b>	<b>Height of Mast Extended w/o LBR (4.5) <sup>1</sup></b>
	<b>in (mm)</b>	<b>in (mm)</b>	<b>in (mm)</b>	<b>in (mm)</b>
<b>R1.4, R1.6</b>	196 (5000)	64 (1648)	87 (2195)	220 (5563)
	206 (5250)	68 (1734)	90 (2281)	229 (5813)
	216 (5500)	71 (1820)	94 (2367)	239 (6063)
	226 (5750)	75 (1906)	97 (2453)	249 (6313)
	236 (6000)	78 (1992)	100 (2539)	259 (6563)
	246 (6250)	81 (2078)	104 (2625)	269 (6813)
	255 (6500)	85 (2164)	107 (2711)	279 (7063)
	265 (6750)	88 (2250)	111 (2797)	288 (7313)
	275 (7000)	91 (2336)	114 (2883)	298 (7563)
	285 (7250)	95 (2422)	117 (2969)	308 (7813)
	295 (7500)	98 (2508)	121 (3055)	318 (8063)
	305 (7750)	102 (2594)	124 (3141)	328 (8313)
	314 (8000)	105 (2680)	128 (3227)	338 (8563)
	324 (8250)	108 (2766)	131 (3313)	347 (8813)
	334 (8500)	112 (2852)	134 (3399)	357 (9063)
	344 (8750)	117 (2938)	138 (3485)	367 (9313)
	354 (9000)	119 (3024)	141 (3571)	377 (9563)
	364 (9250)	122 (3110)	144 (3657)	387 (9813)
	374 (9500)	125 (3196)	148 (3753)	397 (10063)
	383 (9750)	129 (3282)	152 (3839)	407 (10313)
393 (10000)	132 (3368)	155 (3925)	416 (10563)	
403 (10250)	135 (3454)	158 (4011)	426 (10813)	
413 (10500)	139 (3540)	162 (4097)	436 (11063)	
<b>R1.6N</b>				

<sup>1</sup> With load backrest 39.37" height, add 20"; with load backrest 59.06" height, add 39.69".

<b>R2.0, R2.5 - MAST DETAILS, 3-STAGE FULL FREE LIFT</b>			
<b>Lift (4.4)</b>	<b>Free Lift (4.3)</b>	<b>Height of Mast Lowered (4.2)</b>	<b>Height of Mast Extended w/o LBR (4.5) <sup>2</sup></b>
<b>in (mm)</b>	<b>in (mm)</b>	<b>in (mm)</b>	<b>in (mm)</b>
183 (4650)	62 (1582)	87 (2195)	208 (5263)
192 (4900)	65 (1668)	90 (2281)	218 (5513)
202 (5150)	69 (1754)	94 (2367)	227 (5763)
212 (5400)	72 (1840)	97 (2453)	237 (6013)
222 (5650)	75 (1926)	100 (2539)	247 (6263)
232 (5900)	79 (2012)	104 (2625)	257 (6513)
242 (6150)	82 (2098)	107 (2711)	267 (6763)
251 (6400)	85 (2184)	111 (2797)	277 (7013)
261 (6650)	89 (2270)	114 (2883)	286 (7263)
271 (6900)	92 (2356)	117 (2969)	296 (7513)
281 (7150)	96 (2442)	121 (3055)	306 (7763)
291 (7400)	99 (2528)	124 (3141)	316 (8013)
301 (7650)	102 (2614)	128 (3227)	326 (8263)
311 (7900)	106 (2700)	131 (3313)	336 (8513)
320 (8150)	109 (2786)	134 (3399)	345 (8763)

<sup>2</sup> With load backrest 39.37" height, add 17.44"; with load backrest 59.06" height, add 37.12".

<b>R1.6HD - MAST DETAILS, HEAVY DUTY 3-STAGE FULL FREE LIFT</b>			
<b>Lift (4.4)</b>	<b>Free Lift (4.3)</b>	<b>Height of Mast Lowered (4.2)</b>	<b>Height of Mast Extended w/o LBR (4.5) <sup>3</sup></b>
<b>in (mm)</b>	<b>in (mm)</b>	<b>in (mm)</b>	<b>in (mm)</b>
311 (7900)	105 (2680)	128 (3227)	334 (8463)
320 (8150)	108 (2766)	131 (3313)	344 (8713)
330 (8400)	112 (2852)	134 (3399)	353 (8963)
340 (8650)	115 (2938)	138 (3485)	363 (9213)
350 (8900)	119 (3024)	141 (3571)	373 (9463)
360 (8900)	122 (3110)	144 (3657)	383 (9713)
370 (9400)	125 (3196)	148 (3753)	393 (9963)
379 (9650)	129 (3282)	152 (3839)	403 (10213)
389 (9900)	132 (3368)	155 (3925)	412 (10463)
399 (10150)	135 (3454)	158 (4011)	422 (10713)
409 (10400)	139 (3540)	162 (4097)	432 (10963)
419 (10650)	142 (3626)	165 (4183)	442 (11213)
429 (10900)	146 (3712)	169 (4269)	452 (11463)
438 (11150)	149 (3798)	172 (4355)	462 (11713)
448 (11400)	152 (3884)	175 (4441)	471 (11963)

<sup>3</sup> With load backrest 39.37" height, add 20"; with load backrest 59.06" height, add 39.69".

# R SERIES MAST SPECIFICATIONS

R2.0HD - MAST DETAILS, HEAVY DUTY 3-STAGE FULL FREE LIFT			
Lift (4.4)	Free Lift (4.3)	Height of Mast Lowered (4.2)	Height of Mast Extended w/o LBR (4.5) <sup>1</sup>
in (mm)	in (mm)	in (mm)	in (mm)
305 (7750)	102 (2614)	128 (3227)	330 (8363)
314 (8000)	106 (2700)	131 (3313)	340 (8613)
324 (8250)	109 (2786)	134 (3399)	349 (8863)
334 (8500)	113 (2872)	138 (3485)	359 (9113)
344 (8750)	116 (2958)	141 (3571)	369 (9363)
354 (9000)	119 (3044)	144 (3657)	379 (9613)
364 (9250)	123 (3130)	148 (3753)	389 (9863)
374 (9500)	126 (3216)	152 (3839)	399 (10113)
383 (9750)	130 (3302)	155 (3925)	408 (10363)
393 (10000)	133 (3388)	158 (4011)	418 (10613)
403 (10250)	136 (3474)	162 (4097)	428 (10863)
413 (10500)	140 (3560)	165 (4183)	438 (11113)
423 (10750)	143 (3646)	169 (4269)	448 (11363)
433 (11000)	146 (3732)	172 (4355)	458 (11613)
442 (11250)	150 (3818)	175 (4441)	468 (11863)
452 (11500)	153 (3904)	179 (4527)	477 (12113)
462 (11750)	157 (3990)	182 (4613)	487 (12363)
472 (12000)	160 (4076)	185 (4699)	497 (12613)
482 (12250)	163 (4162)	189 (4785)	507 (12863)
492 (12500)	167 (4248)	192 (4871)	517 (13113)
501 (12750)	170 (4334)	196 (4957)	527 (13373)

<sup>1</sup> With load backrest 39.37" height, add 17.44"; with load backrest 59.06" height, add 37.12".

R1.4 TRUCK DIMENSIONS FOR BATTERIES							
1.8	Load distance, center of drive axle to fork	in (mm)	15.81 (402)	12.97 (330)	15.81 (402)	12.97 (330)	10.14 (258)
1.9	Wheelbase	in (mm)	55.12 (1400)	55.12 (1400)	55.12 (1400)	55.12 (1400)	55.12 (1400)
2.1	Service weight	lb (kg)	6861 (3112)	7295 (3309)	6861 (3112)	7319 (3320)	7807 (3541)
2.3	Axle loading, NL front/rear <sup>5</sup>	lb (kg)	4359/ 2502 (1977/1135)	4464/ 2833 (2025/1285)	4359/ 2502 (1977/1135)	4480/ 2842 (2032/1289)	4594/ 3212 (2084/1457)
2.4	Axle loading fork advanced, RL front/rear	lb (kg)	1504/ 8444 (682/3830)	1746/ 8636 (792/3917)	1504/ 8444 (682/3830)	1764/ 8644 (800/3921)	2015/ 8878 (914/4027)
2.5	Axle loading fork retracted, RL front/rear	lb (kg)	3920/ 6030 (1778/2735)	3865/ 6517 (1753/2956)	3920/ 6030 (1778/2735)	3880/ 6526 (1760/2960)	3838/ 7057 (1741/3201)
4.19	Overall length	in (mm)	93.64 (2379)	96.48 (2451)	93.64 (2379)	96.48 (2451)	99.31 (2523)
4.20	Length to face of forks	in (mm)	48.37 (1229)	51.20 (1301)	48.37 (1229)	51.20 (1301)	54.04 (1373)
4.28	Reach distance	in (mm)	23.03 (585)	20.20 (513)	23.03 (585)	20.20 (513)	17.36 (441)
4.34.1	Aisle width for pallets 39.3"x47.2" (1000mm x 1200mm) across - (L6 x b12) <sup>6</sup>	in (mm)	107.01 (2718)	109.09 (2771)	107.01 (2718)	109.09 (2771)	111.26 (2826)
4.34.2	Aisle width for pallets 31.5"x47.2" (800mm x 1200mm) lengthwise - (b12 x L6) <sup>6</sup>	in (mm)	108.82 (2764)	111.38 (2829)	108.82 (2764)	111.38 (2829)	113.98 (2895)
4.34.3	Aisle width for pallets 40" x 48" lengthwise (b12 x L6) <sup>6</sup>	in (mm)	111.54 (2833)	113.97 (2895)	111.54 (2833)	113.97 (2895)	116.46 (2958)
4.34.4	Aisle width for pallets 48" x 48" (b12 x L6) <sup>6</sup>	in (mm)	113.82 (2891)	116.13 (2950)	113.82 (2891)	116.13 (2950)	118.49 (3010)
4.34.5	Aisle width for pallets 48" x 40" across (b12 x L6) <sup>6</sup>	in (mm)	107.74 (2737)	109.81 (2789)	107.74 (2737)	109.81 (2789)	111.97 (2844)
4.35	Turning radius	in (mm)	65.79 (1671)	65.79 (1671)	65.79 (1671)	65.79 (1671)	65.79 (1671)
6.3	Battery according to DIN 43531/35/36 A,B,C, no (reference only)		C	C	C "Super"	C "Super"	C "Super"
6.4	Battery voltage/nominal capacity	V/Ah	48/420	48/560	48/465	48/620	48/775
6.5	Battery weight <sup>4</sup>	lb (kg)	1653 (750)	2070 (939)	1653 (750)	2094 (950)	2568 (1165)

<sup>4</sup> These values may vary of +/- 5%.

RL = Rated Load, NL = No Load

<sup>5</sup> Forks retracted.

<sup>6</sup> Contact your local dealer for AST dimensions with optional cold storage cab

All weights (2.1 to 2.5) are with lowest mast and standard forks.



# R SERIES BATTERY SPECIFICATIONS



R1.6 TRUCK DIMENSIONS FOR BATTERIES							
1.8	Load distance, center of drive axle to fork	in (mm)	17.78 (452)	14.94 (380)	17.78 (452)	14.94 (380)	12.11 (308)
1.9	Wheelbase	in (mm)	57.09 (1450)	57.09 (1450)	57.09 (1450)	57.09 (1450)	57.09 (1450)
2.1	Service weight	lb (kg)	6971 (3162)	7408 (3360)	6971 (3162)	7432 (3371)	7919 (3592)
2.3	Axle loading, NL front/rear <sup>5</sup>	lb (kg)	4449/2522 (2018/1144)	4561/2846 (2069/1291)	4449/2522 (2018/1144)	4579/2853 (2077/1294)	4702/3217 (2133/1459)
2.4	Axle loading fork advanced, RL front/rear	lb (kg)	1325/9176 (601/4162)	1574/9361 (714/4246)	1325/9176 (601/4162)	1590/9370 (721/4250)	1850/9595 (839/4352)
2.5	Axle loading fork retracted, RL front/rear	lb (kg)	4085/6413 (1853/2909)	4023/6911 (1825/3135)	4085/6413 (1853/2909)	4039/6920 (1832/3139)	3988/7458 (1809/3383)
4.19	Overall length	in (mm)	93.64 (2379)	96.48 (2451)	93.64 (2379)	96.48 (2451)	99.31 (2523)
4.20	Length to face of forks	in (mm)	48.37 (1229)	51.20 (1301)	48.37 (1229)	51.20 (1301)	54.04 (1373)
4.28	Reach distance	in (mm)	25.00 (635)	22.17 (563)	25.00 (635)	22.17 (563)	19.33 (491)
4.34.1	Aisle width for pallets 39.3"x47.2" (1000mm x 1200mm) across - (L6 x b12) <sup>6,7</sup>	in (mm)	107.52 (2731)	109.49 (2781)	107.52 (2731)	109.49 (2781)	111.57 (2834)
4.34.2	Aisle width for pallets 31.5"x47.2" (800mm x 1200mm) lengthwise - (b12 x L6) <sup>6,7</sup>	in (mm)	108.94 (2767)	111.42 (2830)	108.94 (2767)	111.42 (2830)	114.02 (2896)
4.34.3	Aisle width for pallets 40" x 48" lengthwise (b12 x L6) <sup>6,7</sup>	in (mm)	111.73 (2838)	114.13 (2899)	111.73 (2838)	114.13 (2899)	116.58 (2961)
4.34.4	Aisle width for pallets 48" x 48" (b12 x L6) <sup>6,7</sup>	in (mm)	114.10 (2898)	116.37 (2956)	114.10 (2898)	116.37 (2956)	118.69 (3015)
4.34.5	Aisle width for pallets 48" x 40" across (b12 x L6) <sup>6,7</sup>	in (mm)	108.22 (2749)	110.21 (2799)	108.22 (2749)	110.21 (2799)	112.31 (2853)
4.35	Turning radius	in (mm)	67.64 (1718)	67.64 (1718)	67.64 (1718)	67.64 (1718)	67.64 (1718)
6.3	Battery according to DIN 43531/35/36 A,B,C, no (reference only)		C	C	C "Super"	C "Super"	C "Super"
6.4	Battery voltage/nominal capacity	V/Ah	48/420	48/560	48/465	48/620	48/775
6.5	Battery weight <sup>4</sup>	lb (kg)	1653 (750)	2070 (939)	1653 (750)	2094 (950)	2568 (1165)

R1.6N TRUCK DIMENSIONS FOR BATTERIES							
1.8	Load distance, center of drive axle to fork	in (mm)	15.02 (382)	11.48 (292)	15.02 (382)	11.48 (292)	7.93 (202)
1.9	Wheelbase	in (mm)	57.09 (1450)	57.09 (1450)	57.09 (1450)	57.09 (1450)	57.09 (1450)
2.1	Service weight	lb (kg)	6859 (3111)	7295 (3309)	6867 (3115)	7313 (3317)	7747 (3514)
2.3	Axle loading, NL front/rear <sup>5</sup>	lb (kg)	4237/2621 (1922/1189)	4292/3003 (1947/1362)	4242/2626 (1924/1191)	4303/3009 (1952/1365)	4332/3415 (1965/1549)
2.4	Axle loading fork advanced, RL front/rear	lb (kg)	1254/9132 (569/4142)	1482/9341 (672/4237)	1261/9134 (572/4143)	1493/9348 (677/4240)	1689/9583 (766/4347)
2.5	Axle loading fork retracted, RL front/rear	lb (kg)	3704/6684 (1680/3032)	3541/7282 (1606/3303)	3708/6687 (1682/3033)	3552/7288 (1611/3306)	3360/7915 (1524/3590)
4.19	Overall length	in (mm)	96.40 (2449)	99.94 (2539)	96.40 (2449)	99.94 (2539)	103.48 (2629)
4.20	Length to face of forks	in (mm)	51.12 (1299)	54.67 (1389)	51.12 (1299)	54.67 (1389)	58.21 (1479)
4.28	Reach distance	in (mm)	22.24 (565)	18.70 (475)	22.24 (565)	18.70 (475)	15.16 (385)
4.34.1	Aisle width for pallets 39.3"x47.2" (1000mm x 1200mm) across - (L6 x b12) <sup>6</sup>	in (mm)	108.74 (2762)	111.34 (2828)	108.74 (2762)	111.34 (2828)	114.13 (2899)
4.34.2	Aisle width for pallets 31.5"x47.2" (800mm x 1200mm) lengthwise - (b12 x L6) <sup>6</sup>	in (mm)	110.67 (2811)	113.90 (2893)	110.67 (2811)	113.90 (2893)	117.17 (2976)
4.34.3	Aisle width for pallets 40" x 48" lengthwise (b12 x L6) <sup>6</sup>	in (mm)	113.35 (2879)	116.42 (2957)	113.35 (2879)	116.42 (2957)	119.56 (3037)
4.34.4	Aisle width for pallets 48" x 48" (b12 x L6) <sup>6</sup>	in (mm)	115.59 (2936)	118.50 (3010)	115.59 (2936)	118.50 (3010)	121.51 (3086)
4.34.5	Aisle width for pallets 48" x 40" across (b12 x L6) <sup>6</sup>	in (mm)	109.45 (2780)	112.08 (2847)	109.45 (2780)	112.08 (2847)	114.86 (2917)
4.35	Turning radius	in (mm)	66.93 (1700)	66.93 (1700)	66.93 (1700)	66.93 (1700)	66.93 (1700)
6.3	Battery according to DIN 43531/35/36 A,B,C, no (reference only)		B	B	B "Super"	B "Super"	B "Super"
6.4	Battery voltage/nominal capacity	V/Ah	48/420	48/560	48/465	48/620	48/775
6.5	Battery weight <sup>4</sup>	lb (kg)	1645 (746)	2066 (937)	1653 (750)	2083 (945)	2502 (1135)

<sup>4</sup> These values may vary of +/- 5%.

RL = Rated Load, NL = No Load

<sup>5</sup> Forks retracted.

<sup>6</sup> Contact your local dealer for AST dimensions with optional cold storage cab

<sup>7</sup> Contact your local dealer for AST dimensions with wide and extra wide frame options

All weights (2.1 to 2.5) are with lowest mast and standard forks.

# R SERIES BATTERY SPECIFICATIONS

R2.0 TRUCK DIMENSIONS FOR BATTERIES					
1.8	Load distance, center of drive axle to fork	in (mm)	16.91 (430)	16.91 (430)	14.07 (358)
1.9	Wheelbase	in (mm)	59.06 (1500)	59.06 (1500)	59.06 (1500)
2.1	Service weight	lb (kg)	7970 (3615)	7994 (3626)	8481 (3847)
2.3	Axle loading, NL front/rear <sup>5</sup>	lb (kg)	4985/2985 (2261/1354)	5000/2994 (2268/1358)	5128/3351 (2326/1520)
2.4	Axle loading fork advanced, RL front/rear	lb (kg)	1479/10897 (671/4943)	1497/10906 (679/4947)	1766/11125 (801/5046)
2.5	Axle loading fork retracted, RL front/rear	lb (kg)	4480/7899 (2032/3583)	4495/7906 (2039/3586)	4414/8477 (2002/3845)
4.19	Overall length	in (mm)	96.48 (2451)	96.48 (2451)	99.31 (2523)
4.20	Length to face of forks	in (mm)	51.20 (1301)	51.20 (1301)	54.04 (1373)
4.28	Reach distance	in (mm)	24.13 (613)	24.13 (613)	21.30 (541)
4.34.1	Aisle width for pallets 39.3"x47.2" (1000mm x 1200mm) across - (L6 x b12) <sup>6,7</sup>	in (mm)	110.04 (2795)	110.04 (2795)	112.05 (2846)
4.34.2	Aisle width for pallets 31.5"x47.2" (800mm x 1200mm) lengthwise - (b12 x L6) <sup>6,7</sup>	in (mm)	111.61 (2835)	111.61 (2835)	114.17 (2900)
4.34.3	Aisle width for pallets 40" x 48" lengthwise (b12 x L6) <sup>6,7</sup>	in (mm)	114.39 (2906)	114.39 (2906)	116.80 (2967)
4.34.4	Aisle width for pallets 48" x 48" (b12 x L6) <sup>6,7</sup>	in (mm)	116.72 (2965)	116.72 (2965)	119.00 (3023)
4.34.5	Aisle width for pallets 48" x 40" across (b12 x L6) <sup>6,7</sup>	in (mm)	110.75 (2813)	110.75 (2813)	112.78 (2865)
4.35	Turning radius	in (mm)	69.57 (1767)	69.57 (1767)	69.57 (1767)
6.3	Battery according to DIN 43531/35/36 A,B,C, no (reference only)		C	C "Super"	C "Super"
6.4	Battery voltage/nominal capacity	V/Ah	48/560	48/620	48/775
6.5	Battery weight <sup>4</sup>	lb (kg)	2070 (939)	2094 (950)	2568 (1165)

R2.5 TRUCK DIMENSIONS FOR BATTERIES					
1.8	Load distance, center of drive axle to fork	in (mm)	19.78 (503)	19.78 (503)	16.95 (431)
1.9	Wheelbase	in (mm)	64.96 (1650)	64.96 (1650)	64.96 (1650)
2.1	Service weight	lb (kg)	8902 (4038)	9004 (4084)	9462 (4292)
2.3	Axle loading, NL front/rear <sup>5</sup>	lb (kg)	5556/3347 (2520/1518)	5626/3377 (2552/1532)	5745/3717 (2606/1686)
2.4	Axle loading fork advanced, RL front/rear	lb (kg)	1704/12710 (773/5765)	1773/12743 (804/5780)	2022/12952 (917/5875)
2.5	Axle loading fork retracted, RL front/rear	lb (kg)	5227/9187 (2371/4167)	5296/9220 (2402/4182)	5176/9797 (2348/4444)
4.19	Overall length	in (mm)	99.51 (2528)	99.51 (2528)	102.34 (2600)
4.20	Length to face of forks	in (mm)	54.23 (1378)	54.23 (1378)	57.07 (1450)
4.28	Reach distance	in (mm)	27.01 (686)	27.01 (686)	24.17 (614)
4.34.1	Aisle width for pallets 39.3"x47.2" (1000mm x 1200mm) across - (L6 x b12) <sup>6</sup>	in (mm)	113.78 (2890)	113.78 (2890)	115.67 (2938)
4.34.2	Aisle width for pallets 31.5"x47.2" (800mm x 1200mm) lengthwise - (b12 x L6) <sup>6</sup>	in (mm)	114.76 (2915)	114.76 (2915)	117.24 (2978)
4.34.3	Aisle width for pallets 40" x 48" lengthwise (b12 x L6) <sup>6</sup>	in (mm)	117.67 (2989)	117.67 (2989)	120.02 (3049)
4.34.4	Aisle width for pallets 48" x 48" (b12 x L6) <sup>6</sup>	in (mm)	120.16 (3052)	120.16 (3052)	122.36 (3108)
4.34.5	Aisle width for pallets 48" x 40" across (b12 x L6) <sup>6</sup>	in (mm)	114.50 (2908)	114.50 (2908)	116.39 (2956)
4.35	Turning radius	in (mm)	75.24 (1911)	75.24 (1911)	75.24 (1911)
6.3	Battery according to DIN 43531/35/36 A,B,C, no (reference only)		C	C "Super"	C "Super"
6.4	Battery voltage/nominal capacity	V/Ah	48/700	48/775	48/930
6.5	Battery weight <sup>4</sup>	lb (kg)	2467 (1119)	2568 (1165)	3016 (1368)

<sup>4</sup> These values may vary of +/- 5%.

RL = Rated Load, NL = No Load

<sup>5</sup> Forks retracted.

<sup>6</sup> Contact your local dealer for AST dimensions with optional cold storage cab

<sup>7</sup> Contact your local dealer for AST dimensions with wide and extra wide frame options

All weights (2.1 to 2.5) are with lowest mast and standard forks.

# R SERIES BATTERY SPECIFICATIONS



R1.6HD TRUCK DIMENSIONS FOR BATTERIES					
1.8	Load distance, center of drive axle to fork	in (mm)	12.11 (308)	12.11 (308)	12.11 (308)
1.9	Wheelbase	in (mm)	57.09 (1450)	57.09 (1450)	57.09 (1450)
2.1	Service weight	lb (kg)	8902 (4038)	8927 (4049)	9414 (4270)
2.3	Axle loading, NL front/rear <sup>5</sup>	lb (kg)	5329/3574 (2417/1621)	5344/3583 (2424/1625)	5417/3997 (2457/1813)
2.4	Axle loading fork advanced, RL front/rear	lb (kg)	1947/10483 (883/4755)	1964/10490 (891/4758)	2224/10717 (1009/4861)
2.5	Axle loading fork retracted, RL front/rear	lb (kg)	4788/7641 (2172/3466)	4806/7648 (2180/3469)	4705/8236 (2134/3736)
4.19	Overall length	in (mm)	99.31 (2523)	99.31 (2523)	99.31 (2523)
4.20	Length to face of forks	in (mm)	54.04 (1373)	54.04 (1373)	54.04 (1373)
4.28	Reach distance	in (mm)	19.33 (491)	19.33 (491)	19.33 (491)
4.34.1	Aisle width for pallets 39.3"x47.2" (1000mm x 1200mm) across - (L6 x b12) <sup>6,7</sup>	in (mm)	111.57 (2834)	111.57 (2834)	111.57 (2834)
4.34.2	Aisle width for pallets 31.5"x47.2" (800mm x 1200mm) lengthwise - (b12 x L6) <sup>6,7</sup>	in (mm)	114.02 (2896)	114.02 (2896)	114.02 (2896)
4.34.3	Aisle width for pallets 40" x 48" lengthwise (b12 x L6) <sup>6,7</sup>	in (mm)	116.58 (2961)	116.58 (2961)	116.58 (2961)
4.34.4	Aisle width for pallets 48" x 48" (b12 x L6) <sup>6,7</sup>	in (mm)	118.69 (3015)	118.69 (3015)	118.69 (3015)
4.34.5	Aisle width for pallets 48" x 40" across (b12 x L6) <sup>6,7</sup>	in (mm)	112.31 (2853)	112.31 (2853)	112.31 (2853)
4.35	Turning radius	in (mm)	67.64 (1718)	67.64 (1718)	67.64 (1718)
6.3	Battery according to DIN 43531/35/36 A,B,C, no (reference only)		C	C "Super"	C "Super"
6.4	Battery voltage/nominal capacity	V/Ah	48/560	48/620	48/775
6.5	Battery weight <sup>4</sup>	lb (kg)	2070 (939)	2094 (950)	2568 (1165)

R2.0HD TRUCK DIMENSIONS FOR BATTERIES					
1.8	Load distance, center of drive axle to fork	in (mm)	13.88 (353)	13.88 (353)	11.04 (281)
1.9	Wheelbase	in (mm)	59.06 (1500)	59.06 (1500)	59.06 (1500)
2.1	Service weight	lb (kg)	9755 (4425)	9857 (4471)	10315 (4679)
2.3	Axle loading, NL front/rear <sup>5</sup>	lb (kg)	5659/4096 (2567/1858)	5725/4131 (2597/1874)	5767/4548 (2616/2063)
2.4	Axle loading fork advanced, RL front/rear	lb (kg)	1964/12200 (891/5534)	2030/12236 (921/5550)	2258/12467 (1024/5655)
2.5	Axle loading fork retracted, RL front/rear	lb (kg)	4927/9235 (2235/4189)	4996/9270 (2266/4205)	4826/9899 (2189/4490)
4.19	Overall length	in (mm)	99.51 (2528)	99.51 (2528)	102.34 (2600)
4.20	Length to face of forks	in (mm)	54.23 (1378)	54.23 (1378)	57.07 (1450)
4.28	Reach distance	in (mm)	21.10 (536)	21.10 (536)	18.27 (464)
4.34.1	Aisle width for pallets 39.3"x47.2" (1000mm x 1200mm) across - (L6 x b12) <sup>6</sup>	in (mm)	112.20 (2850)	112.20 (2850)	114.29 (2903)
4.34.2	Aisle width for pallets 31.5"x47.2" (800mm x 1200mm) lengthwise - (b12 x L6) <sup>6</sup>	in (mm)	114.33 (2904)	114.33 (2904)	116.93 (2970)
4.34.3	Aisle width for pallets 40" x 48" lengthwise (b12 x L6) <sup>6</sup>	in (mm)	116.97 (2971)	116.97 (2971)	119.44 (3034)
4.34.4	Aisle width for pallets 48" x 48" (b12 x L6) <sup>6</sup>	in (mm)	119.16 (3027)	119.16 (3027)	121.51 (3086)
4.34.5	Aisle width for pallets 48" x 40" across (b12 x L6) <sup>6</sup>	in (mm)	112.92 (2868)	112.92 (2868)	115.06 (2923)
4.35	Turning radius	in (mm)	69.57 (1767)	69.57 (1767)	69.57 (1767)
6.3	Battery according to DIN 43531/35/36 A,B,C, no (reference only)		C	C "Super"	C "Super"
6.4	Battery voltage/nominal capacity	V/Ah	48/700	48/775	48/930
6.5	Battery weight <sup>4</sup>	lb (kg)	2467 (1119)	2568 (1165)	3016 (1368)

<sup>4</sup> These values may vary of +/- 5%.

RL = Rated Load, NL = No Load

<sup>5</sup> Forks retracted.

<sup>6</sup> Contact your local dealer for AST dimensions with optional cold storage cab

<sup>7</sup> Contact your local dealer for AST dimensions with wide and extra wide frame options

All weights (2.1 to 2.5) are with lowest mast and standard forks.

# > R SERIES BATTERY SPECIFICATIONS

TRUCK MODEL	COMPARTMENT DIMENSIONS-MAX.			BATTERY DIMENSIONS-MAX.			VOLTS	NO. OF CELLS	AMP HR	WEIGHT	
	WIDTH	LENGTH	HEIGHT	X	Y	Z			CAPACITY	MIN	MAX
	in (mm)	in (mm)	in (mm)	in (mm)	in (mm)	in (mm)			RANGE	lb (kg)	lb (kg)
				+0"/-0.12" (+0/-3)	+0"/-0.12" (+0/-3)	+0"/-0.08" (+0/-2)					
R1.4 - 3,000lb	48.15 (1223)	11.26 (286)	30.94 (786)	48.11 (1222)	11.14 (283)	30.87 (784)	48	24	420-465	1572 (713)	1737 (788)
R1.4 - 3,000lb	48.15 (1223)	14.09 (358)	30.94 (786)	48.11 (1222)	13.98 (355)	30.87 (784)	48	24	560-620	1967 (892)	2200 (998)
R1.4 - 3,000lb	48.15 (1223)	16.93 (430)	30.94 (786)	48.11 (1222)	16.81 (427)	30.87 (784)	48	24	700-775	2344 (1063)	2696 (1223)
R1.6 - 3,500lb	48.15 (1223)	11.26 (286)	30.94 (786)	48.11 (1222)	11.14 (283)	30.87 (784)	48	24	420-465	1572 (713)	1737 (788)
R1.6 - 3,500lb	48.15 (1223)	14.09 (358)	30.94 (786)	48.11 (1222)	13.98 (355)	30.87 (784)	48	24	560-620	1967 (892)	2200 (998)
R1.6 - 3,500lb	48.15 (1223)	16.93 (430)	30.94 (786)	48.11 (1222)	16.81 (427)	30.87 (784)	48	24	700-775	2344 (1063)	2696 (1223)
R1.6N - 3,500lb	40.75 (1035)	14.09 (358)	30.94 (786)	40.71 (1034)	13.90 (353)	30.87 (784)	48	24	420-465	1563 (709)	1737 (788)
R1.6N - 3,500lb	40.75 (1035)	17.56 (446)	30.94 (786)	40.71 (1034)	17.44 (443)	30.87 (784)	48	24	560-620	1962 (890)	2187 (992)
R1.6N - 3,500lb	40.75 (1035)	21.10 (536)	30.94 (786)	40.71 (1034)	20.98 (533)	30.87 (784)	48	24	700-775	2344 (1063)	2628 (1192)
R2.0 - 4,500lb	48.15 (1223)	14.09 (358)	30.94 (786)	48.11 (1222)	13.98 (355)	30.87 (784)	48	24	560-620	1967 (892)	2200 (998)
R2.0 - 4,500lb	48.15 (1223)	16.93 (430)	30.94 (786)	48.11 (1222)	16.81 (427)	30.87 (784)	48	24	700-775	2344 (1063)	2696 (1223)
R2.5 - 5,500lb	48.15 (1223)	16.93 (430)	30.94 (786)	48.11 (1222)	16.81 (427)	30.87 (784)	48	24	700-775	2344 (1063)	2696 (1223)
R2.5 - 5,500lb	48.15 (1223)	19.76 (502)	30.94 (786)	48.11 (1222)	19.65 (499)	30.87 (784)	48	24	840-930	2736 (1241)	3166 (1436)
R1.6HD - 3,500lb	48.15 (1223)	14.09 (358)	30.94 (786)	48.11 (1222)	13.98 (355)	30.87 (784)	48	24	560-620	1967 (892)	2200 (998)
R1.6HD - 3,500lb	48.15 (1223)	16.93 (430)	30.94 (786)	48.11 (1222)	16.81 (427)	30.87 (784)	48	24	700-775	2344 (1063)	2696 (1223)
R2.0HD - 4,500lb	48.15 (1223)	16.93 (430)	30.94 (786)	48.11 (1222)	16.81 (427)	30.87 (784)	48	24	700-775	2344 (1063)	2696 (1223)
R2.0HD - 4,500lb	48.15 (1223)	19.76 (502)	30.94 (786)	48.11 (1222)	19.65 (499)	30.87 (784)	48	24	840-930	2736 (1241)	3166 (1436)
R2.0HD - 4,500lb	46.97 (1193)	19.37 (492)	30.94 (786)	46.85 (1190)	19.22 (488)	30.56 (776)	48	24	980-1085	2866 (1300)	3452 (1566)

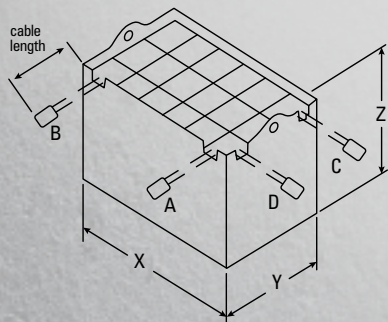

Battery compartment length is measured from front to rear.  
 Battery compartment width is measured across the truck.  
 Battery connector: 350 amp / 48 volt (SB350 blue)  
 Battery lead: length 31.5" (800 mm) "A" position  
 Battery cover - not needed



Hyster Company  
 P.O. Box 7006  
 Greenville, North Carolina  
 27835-7006  
 Part No. RSERIES/TG  
 8/2016 Litho in U.S.A.

Visit us online at [www.hyster.com](http://www.hyster.com) or call us at 1-800-HYSTER-1.

Hyster, and STRONG PARTNERS. TOUGH TRUCKS. are registered trademarks in the United States and certain other jurisdictions. Hyster products are subject to change without notice.

All trucks shown with optional equipment. © 2016 Hyster Company. All rights reserved.