

# L02.5 SERIES



**STRONG PARTNERS.  
TOUGH TRUCKS.™**

**TECHNICAL GUIDE**  
Multi-Level Order Picker

# LO2.5 DIMENSIONS

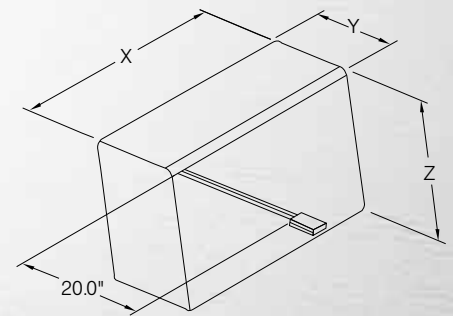
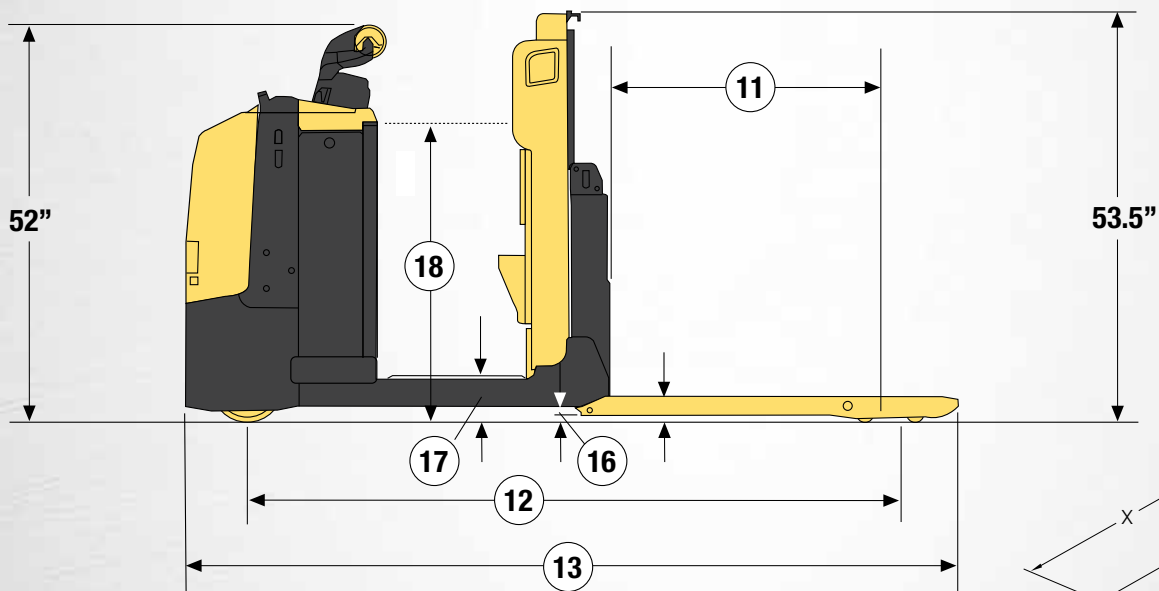
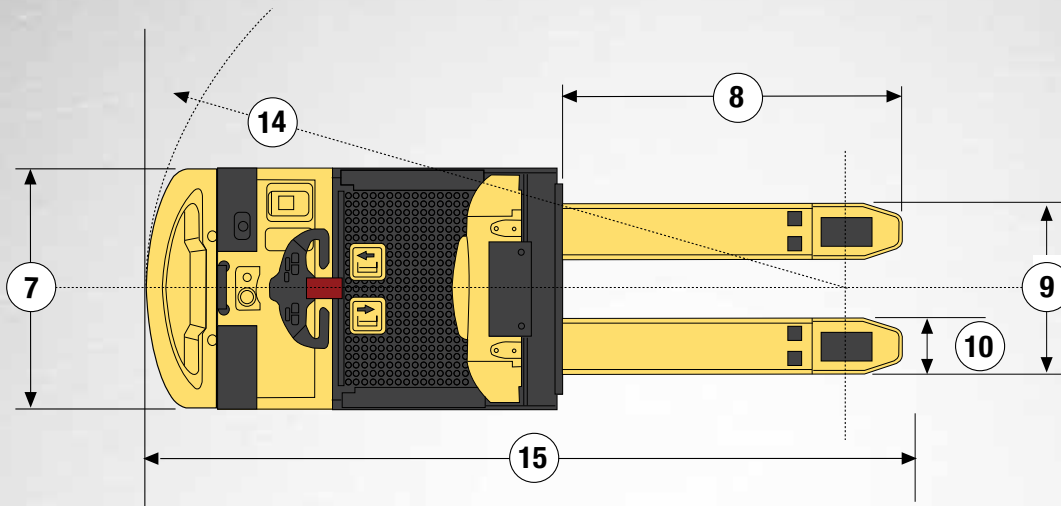

## LO2.5 BATTERY AND COMPARTMENT SPECIFICATIONS

Battery Type	Battery Compartment Dimensions			Battery Dimensions			Number of Cells	Cell Size	Plates per Cell	Capacity 6 Hour Rate	Weight
	Width	Length	Height	"X"	"Y"	"Z"					
	in (mm)			in (mm)						amp hr (kwh)	lbs (kg)
Industrial	31.2 (792.0)	14.1 (357.0)	32.0 (814.0)	26.1 (663)	12.8 (325)	23.3 (592)	12	85	11	425 (9.9)	865 (392)
				30.9 (785)	13.0 (330)	23.3 (592)	12	85	13	510 (11.9)	1035 (469)
				30.9 (785)	13.0 (330)	26.2 (665)	12	100	13	600 (14.0)	1140 (517)

Battery Connector: 175 Amp. Red  
 Battery Lead: Length 20" (508 mm), Position "B", 1/0 AWG

Circled dimensions correspond to the line numbers on the tabulated chart inside the Technical Guide. Dimensions are in inches (millimeters).

# LO2.5 SPECIFICATIONS

GENERAL	1	Manufacturer		HYSTER		
	2	Model Designation		LO2.5		
	3	Power		Battery		
	4	Voltage		34		
	5	Operation		Orderpicker		
	6	Rated Capacity	lbs (kg)	5500 (2500)		
DIMENSIONS	7	Overall Width	in (mm)	31.3 (796)		
	8	Fork Length	in (mm)	46.5 (1181)	94.9 (2411)	
	9	Fork Overall Width	in (mm)	26.4 (670)		
	10	Fork Width - Individual fork	in (mm)	7.2 (184)		
	11	Load Wheel Drop - Lowered	in (mm)	39 (990)	59.8 (1518)	
	12	Wheelbase	in (mm)	79.3 (2015)	100.1 (2543)	
	13	Overall Length	in (mm)	101.9 (990)	150.4 (3819)	
	14	Outside Turning Radius	in (mm)	87.4 (990)	108.1 (1747)	
	15	Equal Aisle	90 Intersecting Aisle	in (mm)	111.3 (990)	111.3 (2827)
	16	Ground Clearance	Center of Wheelbase	in (mm)	1 (25)	
	17	Step Height		in (mm)	6 (152)	
	18	Platform Elevated Height		in (mm)	38.6 (980)	
	19	Battery Compartment	Height / Standard Batt. Rollers	in (mm)	31.2 x 14.1 x 32 (792 x 357 x 814)	
	20	Floor to Top of Battery Rollers	Side Extraction	in (mm)	5.6 (141)	
PERFORMANCE	21	Travel Speed - NL/RL	mph (km/h)	6.5 / 5.3 (10.5 / 8.5)		
	22	Lift Speed - NL/RL	Forks	ft/min (m/sec)	8 / 5 (0.039 / 0.023)	
			Cab	ft/min (m/sec)	37 / 37 (0.189 x 0.189)	
	23	Lower Speed - NL/RL	Forks	ft/min (m/sec)	4 / 7 (0.018 / 0.038)	
			Cab	ft/min (m/sec)	32 / 32 (0.162 / 0.162)	
	24	Gradeability - NL/RL	5 Minute Rating	%	20 / 6	
60 Minute Rating			%	20 / 10		
26	Brake	Service / Parking		Electromagnetic		
WEIGHT	27	Truck Weight - NL	Without Battery	lbs (kg)	2888 (1310)	
	28	Axle Loading - Drive - NL/RL	Static w/ Max. Wt. Battery	lbs (kg)	2154 / 3180 (977 / 1442)	
	29	Axle Loading - Load Wheel- NL/RL	Static with Max. Wt. Battery	lbs (kg)	734 / 5221 (333 / 2368)	
TIRES & WHEELS	30	Tire Type - Drive / Steer		Vulkollan / Polyurethane		
	31	Tire Size - Drive / Steer	Std	in	10 x 3.5 / 10 x 3.5	
	32	Wheels - Number - Drive / Steer	X=Driven		1X / 4	
ELECTRIC	33	Battery	Type	Lead Acid		
	34	Traction Motor	60 Minute Rating	hp (kW)	3.5 (2.6)	
	35	Pump Motor	15 Minute Rating	hp (kW)	2.7 (2)	
	36	Traction Motor	Type / Control Method		AC / Mosfet	
	37	Pump Motor	Type / Control Method		AC / Mosfet	
	38	Number of Speeds	Traction / Pump		Infinitely Variable / Infinitely Variable	

Above specifications, unless otherwise listed, are for a standard truck without optional equipment.

NL=No Load, RL=Rated Load

**CERTIFICATION:** These Hyster® lift trucks meet design specifications of Part II ANSI B56.1-1969, as required by OSHA Section 1910.178(a)(2) and also comply with Part III ANSI B56.1-revision in effect at time of manufacture. Certification of compliance with the applicable ANSI standards appears on the lift truck. Performance specifications are for a truck equipped as described under Standard Equipment on this Technical Guide. Performance specifications are affected by the condition of the vehicle and how it is equipped, as well as by the nature, condition of the operating area, proper service and maintenance of the vehicle. If these specifications are critical, the proposed application should be discussed with your dealer.

# STANDARD FEATURES AND OPTIONS

## L02.5 MULTI-LEVEL ORDER PICKER

Available with fixed or lifting platform, with independent forklift to facilitate ground, first and second level picking.

### PRODUCTIVITY

- The powerful high thermal capacity 2.6kW AC drive motor delivers high performance acceleration, braking and travel speed, making these models ideal for stop and go operations.
- Acceleration, travel and braking speeds can be adjusted by a service engineer to the particular needs of the application through the operator console.
- Effortless electrical steering and automatic speed reduction on cornering ensure excellent control and high productivity.
- The anti-roll back on ramps device ensures efficient operation.
- A maximum travel speed of 6.5 mph reduces travel time on long runs between docking and picking areas.
- The large battery capacity makes these models perfect for dual shift operation while reducing the frequency of battery charging.
- Vertical or lateral battery extraction is available.

### ERGONOMICS

- Scooter control with electric steering reduces the arm movement required to change direction. This allows the operator to remain within the truck footprint at all times for protection as well as reducing operator fatigue and increasing productivity.
- A sensor, which covers the entire platform floor area detects when the operator is on board. This, together with the high, soft touch, back rest, allows the operator to locate the most comfortable operating position.
- The large suspended platform area increases operator comfort and allows easier pass through to optimize picking from both sides.
- Slow-speed forward and reverse direction buttons (coasting function) are located on the backrest. This allows the operator to walk alongside the truck to the next pick location.
- The foot controlled lifting platform option facilitates second level picking. This option reduces the distance the operator has to reach when picking from rack to pallet, reducing fatigue.

### COST OF OWNERSHIP

- Integrated system controls, including the dual technology MOSFET combi-controller, AC traction and DC pump motors increase energy efficiency.
- Adjustable performance settings allow the truck to be tailored to the needs of the application, reducing energy consumption.
- Regenerative braking reduces the use of the service brake and dissipates heat from the traction motor increasing the life of key components.
- Motors and controllers are protected against damage and debris, reducing servicing and repair costs.

### DEPENDABILITY

- The solid frame construction and industrial grade components ensure long-term reliability and durability.
- A sturdy wrap around bumper plate protects the truck against impacts and damage and minimizes repair costs.
- The robust pull rod design of the load wheel axle ensures long term reliability.
- The truck's electronics - including the enclosed AC traction motor, sealed combi-controller (with IP65 rating), sealed electrical connectors and hall effect sensors and switches - are all protected from damage to ensure excellent reliability, maximum productivity and reduced servicing costs.
- Reduced wiring complexity is a result of the CANbus communication system, which also provides easy access to components and delivers world class reliability.

### SERVICEABILITY

- The CANbus system and diagnostics can be controlled and monitored via the console or through the single plug-point. Fault codes can be displayed on the console for easy service identification.
- A one-piece hood provides easy access to key components.
- Full access to the truck's main components, including the motor, is gained by the removal of the motor cover, which is retained by two easily removed screws.
- The low maintenance AC traction motor with built in thermal protection is fully enclosed for protection against damage and debris, minimizing service downtime.

### AVAILABLE OPTIONS INCLUDE:

- Side battery extraction
- Floor-level bumper (rubber bumper)
- Mid-mounted bumper (bull bar)
- Universal support bar on motor compartment
- Various drive wheel compounds, platform lift heights and storage compartments



Hyster Company  
P.O. Box 7006  
Greenville, North Carolina  
27835-7006  
Part No. L02.5/TG  
11/2014 Litho in U.S.A.

Visit us online at [www.hyster.com](http://www.hyster.com) or call us at 1-800-HYSTER-1.

Hyster and  are registered trademarks of Hyster Company.  
Hyster products are subject to change without notice.

The Hyster Company products included in this document may be covered by US Patent 6,684,148, and other patents pending.  
Truck on cover shown with optional equipment. ©2014 Hyster Company. All rights reserved.