



**STRONG PARTNERS.
TOUGH TRUCKS.™**



S40-70FT SERIES TECHNICAL GUIDE

WWW.HYSTER.COM

➤ S40-70FT DIMENSIONS

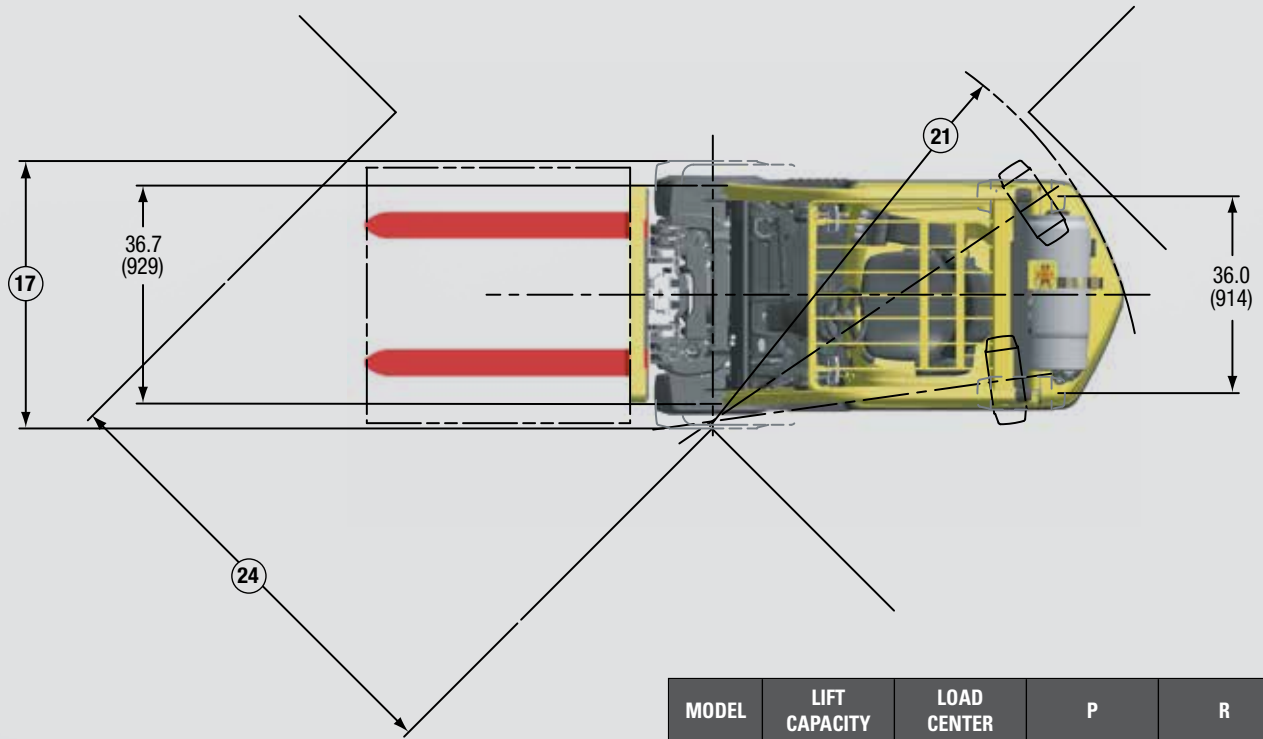

MODEL	LIFT CAPACITY	LOAD CENTER	P	R
	lb (kg)	in (mm)	in (mm)	percent
S40FT	4000 (1814)	24 (610)	16.5 (418)	50%
S50FT	5000 (2268)	24 (610)	18.6 (472)	45%
S55FTS	5500 (2495)	24 (610)	15.9 (405)	47%
S60FT	6000 (2721)	24 (610)	21.3 (541)	39%
S70FT	7000 (3175)	24 (610)	23.3 (591)	39%

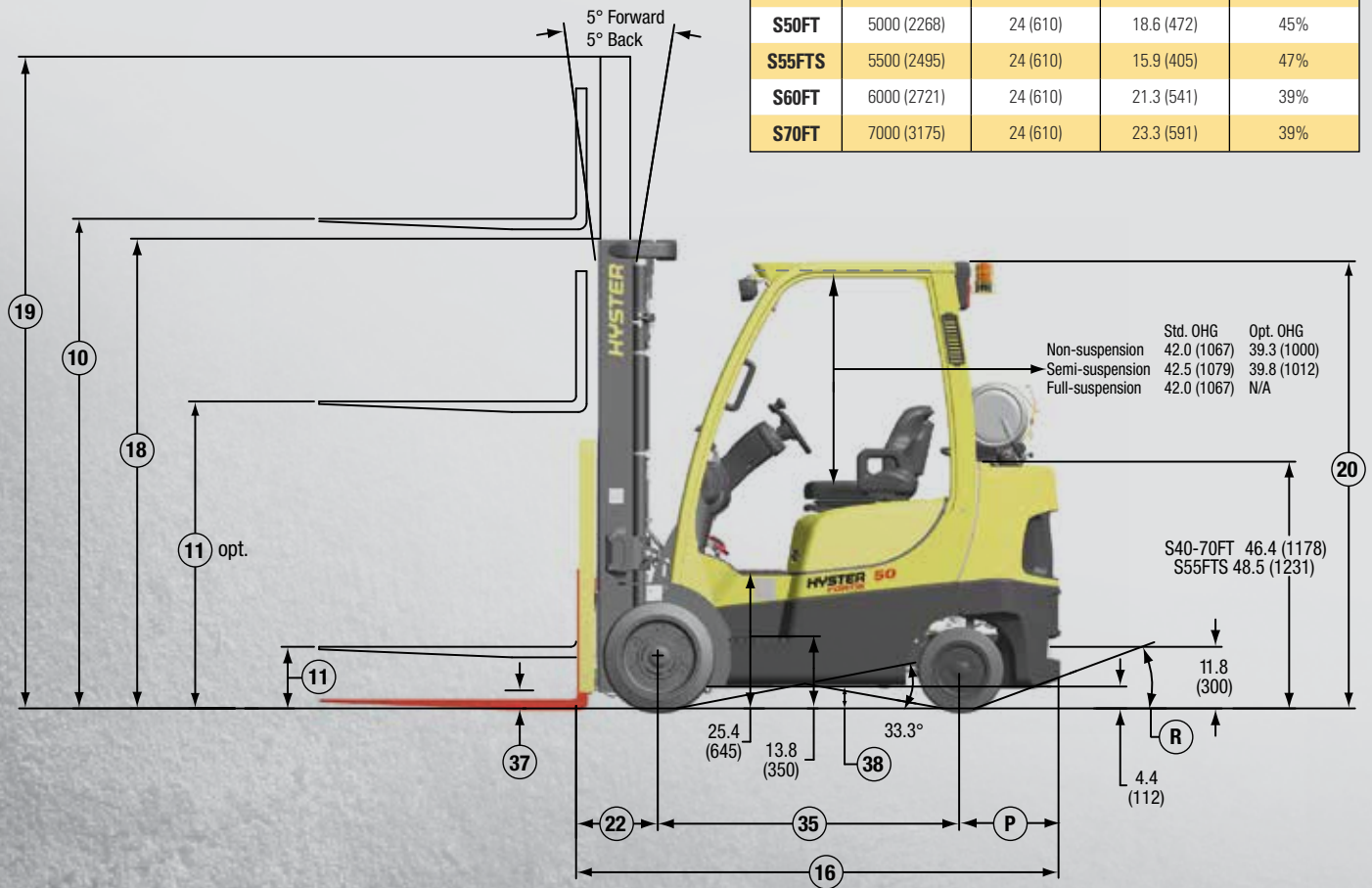

Circled dimensions correspond to the line numbers on the tabulated chart inside the Technical Guide. Dimensions are in inches (millimeters).

S40-55FT SPECIFICATIONS

GENERAL	1	Manufacturer Name	Hyster Company					
	2	Model	S40FT		S50FT		S55FTS	
	3	Engine	PSI 2.4L	Kubota 2.5L	PSI 2.4L	Kubota 2.5L	PSI 2.4L	Kubota 2.5L
	4	Rated Capacity	4000 (1814)		5000 (2268)		5500 (2495)	
	5	Load Center, Distance	24.0 (610)					
	6	Power Type - LPG, Diesel, Dual Fuel	LPG	Dual Fuel	LPG	LPG	Dual Fuel	LPG
	7	Operator Type	Sit-Down Rider			Sit-Down Rider		
	8	Step Height	13.8 (350)			13.8 (350)		
	9	Tire Type - Cushion, Solid, Pneumatic	Cushion			Cushion		
	10	Wheels, Number - Front / Rear	2x/2			2x/2		
DIMENSIONS	11	Lift Height, Top of Fork (TOF)	129 (3292)			129 (3292)		
	12	Lift Heights, Std. Limited Free Lift (LFL) w/o LBR (TOF)	5 (140)			5 (140)		
	13	Lift Heights, Optional Full Free Lift (FFL) w/o LBR (TOF)	62 (1575)			62 (1575)		
	14	Standard Carriage Width	38.5 (980)			38.5 (980)		
	15	Forks, Thickness x Width x Length	1.6 X 3.9 X 42			1.6 X 3.9 X 42		
	16	Forks, Thickness x Width x Length	(40 X 100 X 1067)			(40 x 100 x 1067)		
	17	Fork Spread, Outside Dimensions	38.3 (974)			38.3 (974)		
	18	Mast Tilt Angles, Forward / Backward	5F/5B			5F/5B		
	19	Length To Face of Forks	88.1 (2238)		90.2 (2291)		87.7 (2228)	
	20	Overall Width, Standard Tread	42.0 (1067)			43.6 (1108)		
	21	Overall Width, Wide Tread	48.9 (1242)			48.9 (1242)		
	22	Height, Standard Mast - Lowered	85 (2135)			85 (2135)		
	23	Height, Standard Mast - Extended with LBR	178 (4515)			178 (4515)		
	24	Height, Standard Mast - Extended without LBR	151 (3840)			151 (3840)		
PERFORMANCE	25	Height, Standard Overhead Guard	84 (2128)			84 (2128)		
	26	Height, Optional Overhead Guard	82 (2061)			82 (2061)		
	27	Turning Radius, Minimum Outside (OTR)	76.8 (1950)		78.7 (2000)		76.3 (1937)	
	28	Length, Center of Wheel to Face of Forks	15.4 (390)			15.4 (390)		
	29	Aisle Width, Right Angle Stack (Add Length of Load)	92.1 (2340)		94.1 (2390)		91.6 (2327)	
	30	Equal Aisle, 90-Degree Intersecting Aisle	73.8 (1875)		74.7 (1897)		74.2 (1885)	
	31	Travel Speed, Powershift Transmission RL/NL	10.9/11.3 (17.6/18.2)	11.1/11.2 (17.8/18.0)	10.9/11.3 (17.6/18.2)	11.1/11.2 (17.8/18.0)	10.9/11.3 (17.6/18.2)	11.1/11.2 (17.8/18.0)
	32	Lift Speed, Standard 2-Stage LFL RL/NL	120/124 (.61/.63)	122/126 (.62/.64)	120/124 (.61/.63)	122/126 (.62/.64)	120/124 (.61/.63)	124/126 (.63/.64)
	33	Lift Speed, Optional 2-Stage FFL RL/NL	106/110 (.54/.56)	106/112 (.54/.57)	106/110 (.54/.56)	106/112 (.54/.57)	106/110 (.54/.56)	108/112 (.55/.57)
	34	Lift Speed, Optional 3-Stage FFL RL/NL	112/116 (.57/.59)	114/120 (.58/.61)	112/116 (.57/.59)	114/120 (.58/.61)	112/116 (.57/.59)	116/120 (.59/.61)
	35	Lift Speed, Optional 4-Stage FFL RL/NL	120/124 (.61/.63)	122/126 (.62/.64)	120/124 (.61/.63)	122/126 (.62/.64)	120/124 (.61/.63)	122/126 (.62/.64)
	36	Lowering Speed, Standard 2-Stage LFL RL/NL	114/98 (.58/.50)			114/98 (.58/.50)		
	37	Lowering Speed, Optional 2-Stage FFL RL/NL	98/83 (.50/.42)			98/83 (.50/.42)		
	38	Lowering Speed, Optional 3-Stage FFL RL/NL	106/93 (.54/.47)			106/93 (.54/.47)		
39	Lowering Speed, Optional 4-Stage FFL RL/NL	108/73 (.55/.37)			108/73 (.55/.37)			
40	Maximum drawbar pull RL/NL	5322/1764 (2414/800)	4680/1764 (2123/800)	5282/1676 (2396/760)	4643/1676 (2106/760)	5260/1676 (2386/760)	4623/1676 (2097/760)	
41	Drawbar Pull, Standard Transmission @ 1 mph RL/NL	4453/1764 (2020/800)	4050/1764 (1837/800)	4418/1676 (2004/760)	4012/1676 (1820/760)	4398/1676 (1995/760)	3993/1676 (1811/760)	
42	Gradeability, Standard Transmission @ 1 mph RL/NL	39/24	35/24	33/21	30/21	31/20	28/20	
WT.	43	Weight, Standard Truck (2-Stg. LFL) NL	7803 (3539)		8587 (3895)		9113 (4134)	
	44	Weight, Standard Truck (2-Stg. LFL) RL	11803 (5554)		13587 (6163)		14613 (6628)	
	45	Axle Loading, Static Front / Rear NL	3570/4233 (1619/1920)		3402/5185 (1543/2352)		3454/5659 (1567/2567)	
	46	Axle Loading, Static Front / Rear RL	10366/1437 (4702/652)		11897/1690 (5396/767)		12799/1814 (5806/823)	
TIRES & WHEELS	47	Tire Size, Front	21 X 7 x 15			21 X 8 x 15		
	48	Tire Size, Rear	16 x 5 x 10.5			16 x 6 x 10.5		
	49	Wheelbase	56.3 (1430)			56.3 (1430)		
	50	Ground Clearance, Lowest Point NL (w/RL subtract 6mm)	3.6 (91)			3.6 (91)		
51	Ground Clearance, Center of Wheelbase NL	4.9 (125)			4.9 (125)			
POWERTRAIN	52	Service Brake - Method of Control / Operation	Foot/Hydraulic			Foot/Hydraulic		
	53	Parking Brake - Method of Control / Operation	Hand/Mechanical			Hand/Mechanical		
	54	Battery Type	Maintenance Free			Maintenance Free		
	55	Volts / Cold Cranking Amps	12/475			12/475		
	56	Engine, Manufacturer / Model	PSI 2.4L	Kubota 2.5L	PSI 2.4L	Kubota 2.5L	PSI 2.4L	Kubota 2.5L
	57	Permanent Output @ Rated RPM	59 (44) @ 2700	59 (44) @ 2500	59 (44) @ 2700	59 (44) @ 2500	59 (44) @ 2700	59 (44) @ 2500
	58	Torque @ Rated RPM	121 (16.7) @ 2000	131 (18) @ 1000	121 (16.7) @ 2000	131 (18) @ 1000	121 (16.7) @ 2000	131 (18) @ 1000
	59	Number of Cylinders / Displacement	4/2351 (143)	4/2491 (152)	4/2351 (143)	4/2491 (152)	4/2351 (143)	4/2491 (152)
	60	Transmission Type, Standard	Electronic Powershift			Electronic Powershift		
	61	Standard Speeds, Forward - Reverse	1-1			1-1		
	62	Hydraulic Tank Capacity (Drain and Refill)	9.5 (36.1)			9.5 (36.1)		
63	Fuel Tank Capacity (Dual Fuel - Gasoline)	NA	10.7 (40.5)	NA	10.7 (40.5)	NA	10.7 (40.5)	
64	Auxiliary Hydraulic Pressure Relief for Attachments	PSI (Mpa)			2250 (15.4)			

RL = Rated Load NL = No Load

NOTE: Above specifications, unless otherwise listed, are for a standard truck without optional equipment. Right Angle Stack and Equal Intersecting Aisle are calculated using a 40" wide pallet.

NOTE: Performance specifications / ratings are for truck equipped as described under Standard Equipment in this Technical Guide. Performance specifications are affected by the condition of the vehicle and how it is equipped, as well as by the nature and condition of the operating area. Specifications are subject to change and the proposed application should be discussed with your authorized Hyster Company Dealer.

CERTIFICATION: Hyster lift trucks meet the design and construction requirements of B56.1-1969, per OSHA Section 1910.178(a)(2), and also comply with the B56.1 revision in effect at time of manufacture.

Certification of compliance with the applicable ANSI standards appears on the lift truck.

S60-70FT SPECIFICATIONS

GENERAL	1		Hyster Company			
	2		S60FT		S70FT	
	Engine		PSI 2.4L	Kubota 2.5L	PSI 2.4L	Kubota 2.5L
	Rated Capacity	lb (kg)	6000 (2722)		7000 (3175)	
	Load Center, Distance	in (mm)	24.0 (610)			
	Power Type - LPG, Diesel, Dual Fuel		LPG	Dual Fuel	LPG	Dual Fuel
	Operator Type		Sit-Down Rider			
	Step Height	in (mm)	13.8 (350)			
	Tire Type - Cushion, Solid, Pneumatic		Cushion			
	Wheels, Number - Front / Rear		2x/2			
DIMENSIONS	10	Lift Height, Top of Fork (TOF)	126 (3209)			
	11	Lift Heights, Std. Limited Free Lift (LFL) w/o LBR (TOF)	5 (150)			
		Lift Heights, Optional Full Free Lift (FFL) w/o LBR (TOF)	58 (1490)			
	12	Standard Carriage Width	38.5 (980)			
	13	Forks, Thickness x Width x Length	2.0 X 4.9 X 42			
		Forks, Thickness x Width x Length	(50 X 125 X 1067)			
	14	Fork Spread, Outside Dimensions	38.3 (974)			
	15	Mast Tilt Angles, Forward / Backward	5F/5B			
	16	Length To Face of Forks	93.4 (2373)		95.6 (2429)	
	17	Overall Width, Standard Tread	43.6 (1108)		45.6 (1158)	
		Overall Width, Wide Tread	48.9 (1242)			
	18	Height, Standard Mast - Lowered	87 (2185)			
	19	Height, Standard Mast - Extended with LBR	175 (4435)			
		Height, Standard Mast - Extended without LBR	152 (3855)			
	20	Height, Standard Overhead Guard	84 (2128)			
		Height, Optional Overhead Guard	82 (2061)			
	21	Turning Radius, Minimum Outside (OTR)	81.3 (2066)			
	22	Length, Center of Wheel to Face of Forks	15.8 (402)		15.8 (402)	
23	Aisle Width, Right Angle Stack (Add Length of Load)	97.2 (2468)		99.3 (2521)		
24	Equal Aisle, 90-Degree Intersecting Aisle	76.5 (1943)		78.2 (1986)		
PERFORMANCE	25	Travel Speed, Powershift Transmission RL/NL	10.6/11.2 (17.0/18.0)	11.1/11.2 (17.8/18.0)	10.6/11.2 (17.0/18.0)	11.1/11.2 (17.8/18.0)
	26	Lift Speed, Standard 2-Stage LFL RL/NL	104/108 (.53/.55)	108/110 (.55/.56)	104/108 (.53/.55)	110/110 (.56/.56)
		Lift Speed, Optional 2-Stage FFL RL/NL	102/106 (.52/.54)	104/106 (.53/.54)	102/106 (.52/.54)	104/106 (.53/.54)
		Lift Speed, Optional 3-Stage FFL RL/NL	100/104 (.51/.53)	100/104 (.51/.53)	100/104 (.51/.53)	102/104 (.52/.53)
		Lift Speed, Optional 4-Stage FFL RL/NL	120/124 (.61/.63)	122/126 (.62/.64)	N/A	
	27	Lowering Speed, Standard 2-Stage LFL RL/NL	104/93 (.53/.47)		104/93 (.53/.47)	
		Lowering Speed, Optional 2-Stage FFL RL/NL	98/83 (.50/.42)		98/83 (.50/.42)	
		Lowering Speed, Optional 3-Stage FFL RL/NL	114/95 (.58/.48)		114/95 (.58/.48)	
		Lowering Speed, Optional 4-Stage FFL RL/NL	108/73 (.55/.37)		N/A	
	28	Maximum drawbar pull RL/NL	5234/1821 (2374/826)	4597/1821 (2085/826)	5172/1709 (2346/775)	4559/1709 (2068/775)
	Drawbar Pull, Standard Transmission @ 1 mph RL/NL	4372/1821 (1983/826)	3968/1821 (1800/826)	4321/1709 (1960/775)	3931/1709 (1783/775)	
29	Gradeability, Standard Transmission @ 1 mph RL/NL	28/19	25/19	25/17	23/17	
WT.	31	Weight, Standard Truck (2-Stg. LFL) NL	9768 (4431)		10535 (4779)	
		Weight, Standard Truck (2-Stg. LFL) RL	15767 (7152)		17535 (7954)	
	32	Axle Loading, Static Front / Rear NL	3474/6294 (1576/2855)		3269/7266 (1483/3296)	
		Axle Loading, Static Front / Rear RL	13718/2049 (6222/929)		15221/2314 (6904/1050)	
TIRES & WHEELS	33	Tire Size, Front	21 X 8 x 15		21 X 9 x 15	
	34	Tire Size, Rear	16 x 6 x 10.5			
	35	Wheelbase	56.3 (1430)			
	37	Ground Clearance, Lowest Point NL (w/RL subtract 6mm)	3.6 (91)			
	38	Ground Clearance, Center of Wheelbase NL	4.9 (125)			
	39	Service Brake - Method of Control / Operation	Foot/Hydraulic			
40	Parking Brake - Method of Control / Operation	Hand/Mechanical				
POWERTRAIN	41	Battery Type	Maintenance Free			
	42	Volts / Cold Cranking Amps	12/475			
	43	Engine, Manufacturer / Model	PSI 2.4L	Kubota 2.5L	PSI 2.4L	Kubota 2.5L
	44	Permanent Output @ Rated RPM	59 (44) @ 2700		59 (44) @ 2700	
	45	Torque @ Rated RPM	121 (16.7) @ 2000		121 (16.7) @ 2000	
	46	Number of Cylinders / Displacement	4/2351 (143)		4/2491 (152)	
	47	Transmission Type, Standard	Electronic Powershift			
		Standard Speeds, Forward - Reverse	1-1			
	49	Hydraulic Tank Capacity (Drain and Refill)	9.5 (36.1)			
	50	Fuel Tank Capacity (Dual Fuel - Gasoline)	NA	10.7 (40.5)	NA	10.7 (40.5)
	51	Auxiliary Hydraulic Pressure Relief for Attachments	PSI (Mpa)			
		2250 (15.4)				

RL = Rated Load NL = No Load

NOTE: Above specifications, unless otherwise listed, are for a standard truck without optional equipment. Right Angle Stack and Equal Intersecting Aisle are calculated using a 40" wide pallet.

NOTE: Performance specifications / ratings are for truck equipped as described under Standard Equipment in this Technical Guide. Performance specifications are affected by the condition of the vehicle and how it is equipped, as well as by the nature and condition of the operating area. Specifications are subject to change and the proposed application should be discussed with your authorized Hyster Company Dealer.

CERTIFICATION: Hyster lift trucks meet the design and construction requirements of B56.1-1969, per OSHA Section 1910.178(a)(2), and also comply with the B56.1 revision in effect at time of manufacture. Certification of compliance with the applicable ANSI standards appears on the lift truck.

S40-70FT MAST SPECIFICATIONS

S40-55FT MAST DIMENSIONS							
Maximum Fork Height (TOF) †	Overall Lowered Height	Overall Extended Height		Free Lift (TOF)	Approximate Total Weight of Standard Equipped Truck w/o Load		
		with LBR	without LBR	without LBR*	S40FT	S50FT	S55FTS
in (mm)	in (mm)	in (mm)	in (mm)	in (mm)	lbs (kg)	lbs (kg)	lbs (kg)
2-STAGE LIMITED FREE LIFT (LFL) VISTA™ PLUS MAST							
82 (2092)	61 (1535)	131 (3315)	104 (2650)	5 (140)	7596 (3445)	8380 (3801)	8906 (4040)
129 (3292)	85 (2135)	178 (4515)	151 (3840)	5 (140)	7803 (3539)	8587 (3895)	9133 (4134)
2-STAGE FULL FREE LIFT (FFL) VISTA™ MAST							
130 (3302)	85 (2135)	179 (4525)	152 (3860)	62 (1575)	7840 (3556)	8624 (3912)	9150 (4150)
3-STAGE FULL FREE LIFT (FFL) VISTA™ PLUS MAST							
171 (4350)	77 (1935)	220 (5575)	193 (4890)	54 (1395)	8085 (3668)	8869 (4023)	9395 (4262)
189 (4800)	83 (2085)	238 (6025)	210 (5340)	60 (1545)	8160 (3702)	8944 (4057)	9470 (4296)
194 (4950)	85 (2135)	244 (6175)	216 (5490)	62 (1595)	8185 (3713)	8969 (4069)	9495 (4307)
200 (5100)	88 (2235)	249 (6325)	222 (5640)	66 (1695)	8234 (3735)	9018 (4090)	9544 (4329)
218 (5550)	94 (2385)	267 (6775)	240 (6090)	84 (2145)	8314 (3771)	9098 (4127)	9624 (4365)
4-STAGE FULL FREE LIFT (FFL) VISTA™ MAST**							
240 (6095)	84 (2135)	289 (7321)	262 (6641)	59 (1513)	8694 (3944)	9478 (4299)	10004 (4538)
276 (7013)	96 (2437)	322 (8184)	298 (7556)	71 (1817)	8889 (4032)	9673 (4388)	10199 (4626)

† Lift heights over 171.5" (4356 mm) maximum fork height are considered highlifts and require reduced capacity and restricted back tilt.
 * On 2-stage FFL and 3-stage FFL mast, subtract 26" (665 mm) if Load Backrest (LBR) is used.
 ** Lift trucks equipped with the 4-stage FFL mast require Class II carriage and forks.

S60-70FT MAST DIMENSIONS						
Maximum Fork Height (TOF) †	Overall Lowered Height	Overall Extended Height		Free Lift (TOF)	Approximate Total Weight of Standard Equipped Truck w/o Load	
		with LBR	without LBR	without LBR*	S60FT	S70FT
in (mm)	in (mm)	in (mm)	in (mm)	in (mm)	lbs (kg)	lbs (kg)
2-STAGE LIMITED FREE LIFT (LFL) VISTA™ PLUS MAST						
126 (3209)	86 (2185)	175 (4435)	152 (3855)	5 (150)	9768 (4431)	10535 (4779)
2-STAGE FULL FREE LIFT (FFL) VISTA™ MAST						
122 (3110)	85 (2135)	171 (4335)	148 (3755)	58 (1490)	9785 (4438)	10552 (4787)
130 (3310)	88 (2235)	179 (4535)	156 (3955)	62 (1590)	9822 (4455)	10589 (4803)
3-STAGE FULL FREE LIFT (FFL) VISTA™ PLUS MAST						
181 (4618)	85 (2135)	231 (5845)	207 (5245)	59 (1505)	10128 (4594)	10896 (4942)
187 (4768)	88 (2235)	236 (5995)	212 (5395)	63 (1595)	10173 (4614)	10941 (4963)
211 (5368)	98 (2485)	260 (6595)	236 (5995)	73 (1855)	10308 (4676)	11076 (5024)
229 (5818)	104 (2635)	278 (7045)	254 (6445)	79 (2005)	10498 (4762)	11266 (5110)
4-STAGE FULL FREE LIFT (FFL) VISTA™ MAST**						
240 (6095)	84 (2135)	289 (7321)	262 (6641)	59 (1513)	10486 (4757)	N / A
276 (7013)	96 (2437)	322 (8184)	298 (7556)	71 (1817)	10681 (4845)	N / A

† Lift heights over 164.0" (4166 mm) maximum fork height are considered highlifts and require reduced capacity and restricted back tilt.
 * On 2-stage FFL and 3-stage mast, subtract 23" (585 mm) if Load Backrest (LBR) is used.
 ** Lift trucks equipped with the 4-stage FFL mast require Class II carriage and forks.

➤ S40-70FT RATED CAPACITIES

RATED LOAD vs. LOAD CENTER
STANDARD CARRIAGE
U. S. CUSTOMARY

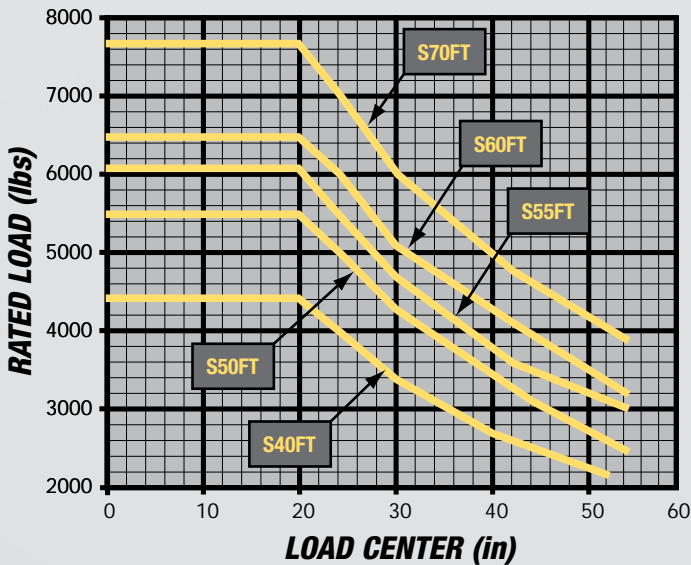

RATED LOAD vs. LOAD CENTER
INTEGRAL SIDESHIFT ATTACHMENT
U. S. CUSTOMARY

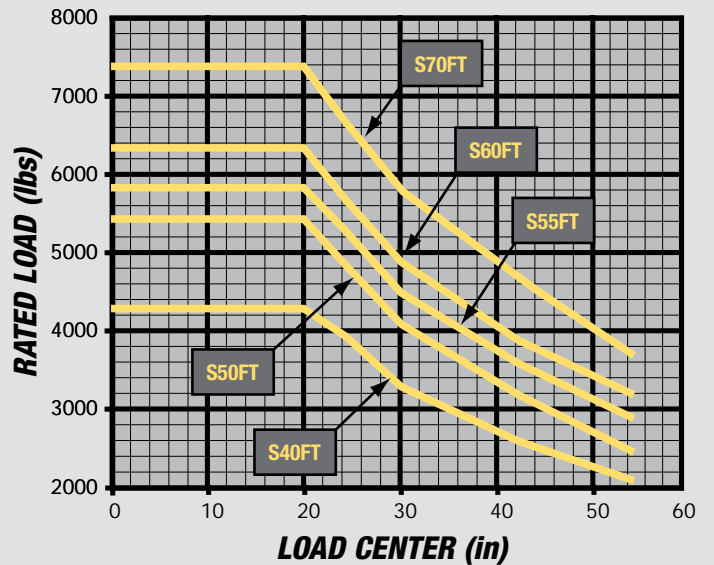

RATED LOAD vs. LOAD CENTER
STANDARD CARRIAGE
METRIC

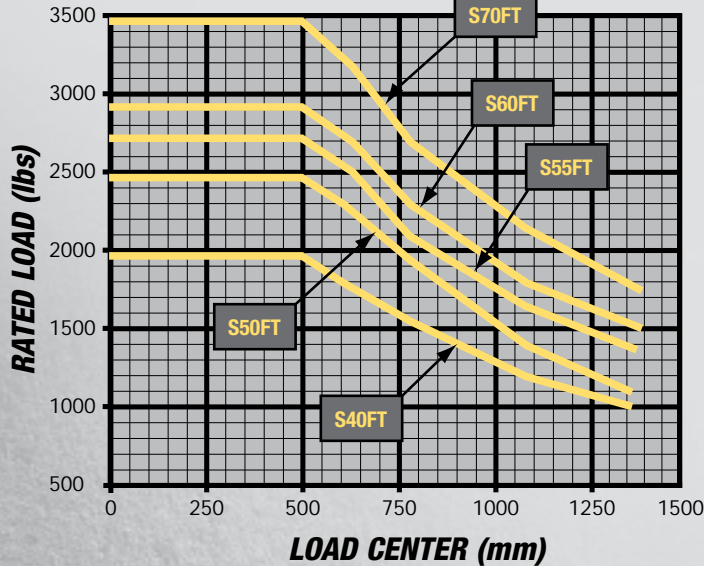

RATED LOAD vs. LOAD CENTER
INTEGRAL SIDESHIFT ATTACHMENT
METRIC

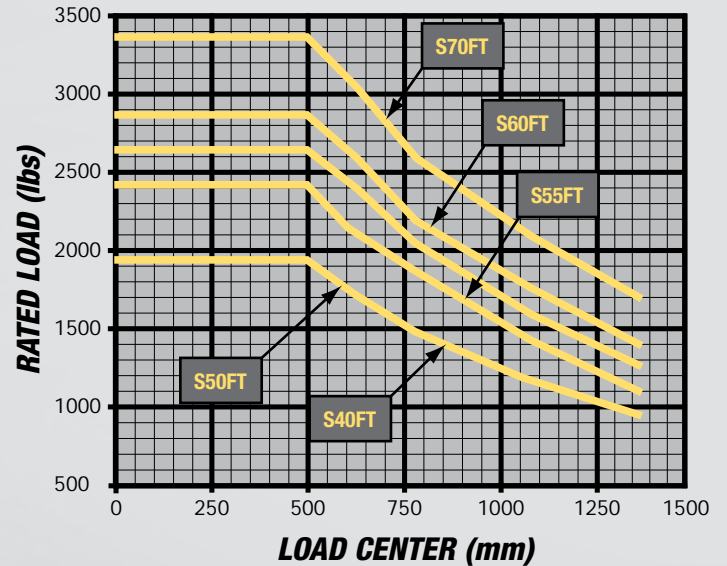

TRUCK CONFIGURATION:

- 3-stage FFL mast at highest non-highlift (HNHL) 171.0" (4350 mm) maximum fork height (MFH) for S40-50FT and 164.0" (4170 mm) for S60-70FT.
- 42.0" (1067 mm) standard carriage with load backrest (LBR).
- Basic truck equipped with the PSI 2.4L LPG engine with one-speed electronic powershift transmission.

STANDARD EQUIPMENT

PSI 2.4L LPG engine
 PSI 2.4L LPG emissions compliant engine
 Basic electronic powershift transmission

- Electronic inching
- Electronic shift control
- Neutral start switch
- Anti-restart protection

 MONOTROL® pedal
 2-stage limited free lift VISTA™PLUS mast with maximum fork height of 129" (3277 mm) (S40-50FT, S55FTS) or 126" (3209 mm) (S60-70FT)
 38.5" (978 mm) wide hook-type carriage with load backrest
 42" (1067 mm) long forks
 5 degrees forward / 5 degrees backward mast tilt
 3-function hydraulic control valve
 Hydraulic power steering (hydrostatic)
 Non-suspension vinyl seat
 Electronic horn
 Infinitely adjustable steer column
 Rubber floor mat
 High air intake
 Integral tie downs
 Operator restraint system with non-cinch ELR seat belt
 Square-wave, anti-clog radiator
 Single pedal inch brake
 Integrated dashboard display includes:

- LCD Display:
 - Fuel level
 - Hour meter
 - Coolant temperature
 - Messages
- Service Indicator Lights:
 - Alternator
 - Transmission oil temperature
 - Engine oil pressure
 - Brake fluid level
 - Fasten seat belt
 - Low fuel level
 - Engine malfunction
 - System malfunction
 - Park brake
 - Coolant temp
 - Forward & reverse direction
 - Neutral

 Hyster Stability System (HSS®)
 Cowl-mounted hydraulic hand levers
 Swing-out LPG tank bracket
 84" (2128 mm) overhead guard
 12 months / 2,000 hours manufacturer's warranty
 24 months / 4,000 hours manufacturer's powertrain warranty
 Operator's manual
 UL Classification LP

OPTIONAL EQUIPMENT

PSI 2.4L dual fuel engine
 Kubota 2.5L LPG engine
 DuraMatch™ transmission

- Auto Deceleration System
- Controlled power reversal feature
- Controlled rollback on ramps

 Powertrain protection system
 Premium electronic monitoring
 High air intake with precleaner
 Accumulator
 Keyless start (with auxiliary key switch)
 Halogen or LED drive and rear work lights
 Heavy duty radiator with combi-cooler
 Paper applications kit
 Integral sideshifting fork positioner
 Vented hood
 Swing-out, drop-down EZXchange LPG tank bracket
 TouchPoint electro-hydraulic controls with fully adjustable armrest
 Return-to-set tilt
 Rear drive handle with horn button
 Full-suspension seat - vinyl or cloth
 Swivel full-suspension seat - vinyl or cloth
 High-visibility non-cinch seat belt with or without interlock
 Dual inch brake pedals
 Password protection
 Low height overhead guard 82" (2061 mm)
 Audible alarm - reverse activated 82-102 dB(A) - self-adjusting
 Visible alarm amber strobe light - continuous activated, OHG mounted
 Various light packages

- Two front and one rear halogen or LED work lights
- Two front, one rear halogen or LED work lights and two LED brake/tail/back-up lights

 UL Classification LPS or LPS/GS
 Operator pre-shift checklist
 Impact monitor
 Load weight display
 Dual side view mirrors
 Integral sideshifter



Hyster Company
P.O. Box 7006
Greenville, North Carolina
27835-7006
Part No. S40-70FT/TG
4/2017 Litho in U.S.A.

Visit us online at www.hyster.com or call us at **1-800-HYSTER-1**.

Hyster, , and STRONG PARTNERS. TOUGH TRUCKS. and MONOTROL are registered trademarks in the United States and certain other jurisdictions. Hyster products are subject to change without notice.

Trucks may be shown with optional equipment. © 2017 Hyster Company. All rights reserved.